

GPS/GNSS Antenna Module

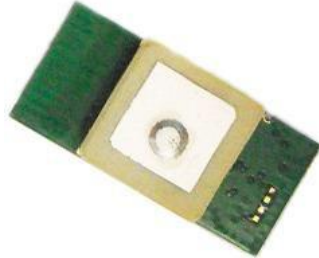

1. Product Information

1.1 Product Name: YIC52813GM-37

1.2 Product Description:

YIC52813GM-37 is a compact, high performance, and low power consumption GNSS engine board.

It uses the chipset which can track up to 56 channels at a time and perform fast TTFF in weak signal environments.

YIC52813GM-37 is suitable for the following applications:

- Automotive navigation
- Personal positioning
- Fleet management
- Mobile phone navigation
- Marine navigation

1.3 Product Features:

- High performance and low power consumption GPS Chipset
- Very high sensitivity
- Extremely fast TTFF (Time To First Fix) at low signal level
- Built-in LNA
- Compact size suitable for space-sensitive application
- Support NMEA 0183 and ublox binary protocol

1.4 Product Specifications

GNSS Performance

GNSS Performance	
Chipset	MTK3337 (ROM)
Frequency	GPS, GALILEO, QZSS: L1 1575.42MHz, C/A code or GLONASS: L1 1598.0625MHz ~ 1605.375MHz, C/A code AS
Code	C/A Code
Protocol	NMEA 0183 Default:GGA,GSA,GSV,RMC Support:VTG,GLL,TXT binary and NMEA Command
Available Baud Rate	9,600 bps
Channels	72
Sensitivity	Tracking:-167dBm Reacquisition:-160dBm ColdStart:-148dBm HotStart:-156dBm
Cold Start	26 seconds, average
Aided Start	2 seconds, average
Hot Start	1 second, average
Accuracy	HorizontalPosition:Autonomous<2.5m average, SBAS < 2.0m average Velocity: 0.1 m/s Timepulse signal: RMS 30 ns
Maximum Altitude	<18,000 meter
Maximum Velocity	500 m/s(1000 knots)
Dynamics	≦ 4G
Update Rate	Single GNSS up to 18Hz Concurrent GNSS up to 10Hz
A-GPS	AssistNow on-line and off-line
Interface	
I/O Pins	1 serial ports
Physical Characteristic	
Dimensions	28.1mm * 13.1 mm * 8.7mm

1.5 DC Electrical characteristics

Parameter	Symbol	Conditions	Min.	Typ.	Max.	Units
Input Voltage	VCC		3.0	3.3	5.5	V
Input Backup Battery Voltage	V_BCKP		2.0		3.6	V
Supply Current	I _{ss}	VCC = 3.3V, w/o active antenna, Peak Acquisition Tracking Standby		23 15 ⁽²⁾ 360	150 ⁽¹⁾	mA mA mA uA
Backup Battery Current	I _{bat}	VCC = 0V		7		uA
High Level Input Voltage	V _{IH}		2.0		3.6	V
Low Level Input Voltage	V _{IL}		-0.3		0.8	V
High Level Input Current	I _{IH}	no pull-up or down	-1		1	uA
Low Level Input Current	I _{IL}	no pull-up or down	-1		1	uA
High Level Output Voltage	V _{OH}		2.4		3.3	V
Low Level Output Voltage	V _{OL}				0.4	V
High Level Output Current	I _{OH}			2		mA
Low Level Output Current	I _{OL}			2		mA

Note 1: This happens when downloading AGPS data to Module.

Note 2: Measured when position fix (1Hz) is available, input voltage is 3.3V and the function of self-generated ephemeris prediction is inactive.

Temperature characteristics

Parameter	Symbol	Min.	Typ.	Max.	Units
Operating Temperature	T _{opr}	-40	25	85	°C
Storage Temperature	T _{stg}	-40	25	85	°C

2. Module Pin Assignment & Dimensions

2.1 Module Pin Assignment

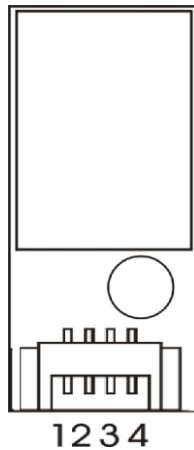

Pin NO.	Pin Name	I/O	Remark
1.	Vcc	I	+3.0V ~ 5.5V
2.	TXD	O	UART Series Data Output
3.	RXD	I	UART Series Data Input
4.	GND	G	Ground.

2.2 Dimensions

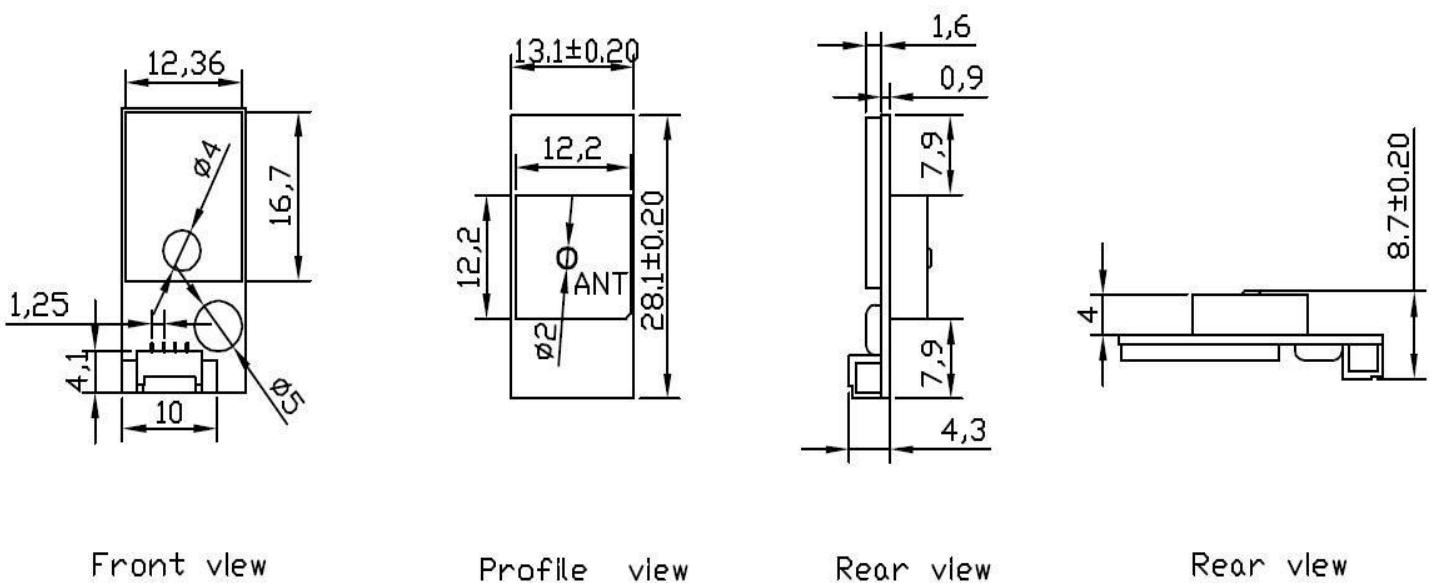

3. Application guideline

Layout Rules

Do not routing the other signal or power trace under the engine board .

Design Notes

GND

Ground pin for the baseband circuit.

RXD

This is the main channel for receiving software commands from u-blox software or from your proprietary software.

TXD

This is the main transmits channel for outputting navigation and measurement data to user's navigation software or user written software.

4.NMEA 0183 Protocol

The NMEA protocol is an ASCII-based protocol, Records start with a \$ and with carriage return/line feed. GPS specific messages all start with \$GPxxx where xxx is a three-letter identifier of the message data that follows. NMEA messages have a checksum, which allows detection of corrupted data transfers.

YIC52813GM-37 modules support the following NMEA-0183 messages: GGA, GLL, GSA, GSV, RMC and VTG.

Table 1: NMEA-0183 Output Messages

NMEA Record	DESCRIPTION
GGA	Global positioning system fixed data
GLL	Geographic position—latitude/longitude
GSA	GNSS DOP and active satellites
GSV	GNSS satellites in view
RMC	Recommended minimum specific GNSS data
VTG	Course over ground and ground speed

GGA-Global Positioning System Fixed Data

Table 2 contains the values of the following example:

\$GPGGA, 161229.487,3723.24751,N, 12158.34160,W, 1,07,1.0,9.0,M.0000*18

Table 2: GGA Data Format

Name	Example	Units	Description
Message ID	\$GPGGA		GGA protocol header
UTC Position	161229.487		hhmmss.sss
Latitude	3723.24571		ddmm.mmmmm
N/S indicator	N		N=north or S=south
Longitude	12158.34160		ddmm.mmmmm
E/W Indicator	W		E=east or W=west
Position FixIndicator	1		See Table 2-1
Satellites Used	07		Range 0 to 12
HDOP	1.0		Horizontal Dilution of Precision
MSLAltitude	9.0	meters	
Units	M	meters	
Geoids Separation		meters	
Units	M	meters	
Age of Diff.Corr.		second	Null fields when DGPS is not Used
Diff.Ref.Station ID	0000		
Checksum	*18		
<CR><LF>			End of message termination

Table 2-1: Position Fix Indicators

Value	Description
0	Fix not available or invalid
1	GPS SPS Mode, fix valid
2	Differential GPS, SPS Mode, fix valid
3	GPS PPS Mode, fix valid

GLL-Geographic Position – Latitude/Longitude

Table 3 contains the values of the following example:

\$GPGLL , 3723.24755, N,12158.34161,W,161229.487, A*2C.

Table 3: GLL Data Format

Name	Example	Units	Description
Message ID	\$GPGLL		GLL protocol header
Latitude	3723.24755		Ddmm.mmmmm
N/S Indicator	N		N=north or S=south
Longitude	12158.34161		ddmm.mmmmm
E/W Indicator	W		E=east or W=west
UTC Position	161229.487		Hhmmss.sss
Status	A		A=data valid or V=data not valid
Checksum	*2C		
<CR><LF>			End of message termination

GSA-GNSS DOP and Active Satellites

Table 4 contains the values of the following example:

\$GPGSA , A, 3, 07, 02, 26,27, 09, 04,15, , , , , 1.8,1.0,1.5*33.

Table 4: GSA Data Format

Name	Example	Units	Description
Message ID	\$GPGSA		GSA protocol header
Mode 1	A		See Table 4-1
Mode 2	3		See Table 4-2
Satellite Used	07		Sv on Channel 1
Satellite Used	02		Sv on Channel 2
...
Satellite Used			Sv on Channel 12
PDOP	1.8		Position Dilution of Precision
HDOP	1.0		Horizontal Dilution of Precision
VDOP	1.5		Vertical Dilution of Precision
Checksum	*33		
<CR><LF>			End of message termination

Table 4-1: Mode 1

Value	Description
1	Fix not available
2	2D
3	3D

Table 4-2: Mode 2

Value	Description
M	Manual-forced to operate in 2D or 3D mode
A	Automatic-allowed to automatically switch 2D/3D

GSV-GNSS Satellites in View

Table 5 contains the values of the following example:

\$GPGSV , 2, 1, 07, 07, 79,048, 42, 02, 51,062, 43, 26, 36,256, 42, 27, 27, 138,42*71

\$GPGSV , 2, 2, 07, 09, 23,313, 42, 04, 19, 159, 41, 15,12,041, 42*41.

Table 5: GGA Data Format

Name	Example	Units	Description
Message ID	\$GPGSV		GSV protocol header
Number of Message	2		Range 1 to 3
Message Number	1		Range 1 to 3
Satellites in View	07		
Satellite ID	07		Channel 1(Range 1 to 32)
Elevation	79	degrees	Channel 1(Maximum 90)
Azimuth	048	degrees	Channel 1(True, Range 0 to 359)
SNR(C/NO)	42	dBHz	Range 0 to 99,null when not tracking
...			...
Satellite ID	27		Channel 4(Range 1 to 32)
Elevation	27	degrees	Channel 4(Maximum 90)
Azimuth	138	degrees	Channel 4(True, Range 0 to 359)
SNR(C/NO)	42	dBHz	Range 0 to 99, null when not tracking
Checksum	*71		
<CR><LF>			End of message termination

Depending on the number of satellites tracked multiple messages of GSV data may be required

RMC-Recommended Minimum Specific GNSS Data

Table 6 contains the values of the following example:

\$GPRMC, 161229.487, A, 3723.24751, N, 12158.34161, W, 0.13, 309.62, 120598, , *10

Table 6: RMC Data Format

Name	Example	Units	Description
Message ID	\$GPRMC		RMC protocol header
UTS Position	161229.487		hhmmss.sss
Status	A		A=data valid or V=data not valid
Latitude	3723.24751		ddmm.mmmmm
N/S Indicator	N		N=north or S=south
Longitude	12158.34161		Ddmm.mmmmm
E/W Indicator	W		E=east or W=west
Speed Over Ground	0.13	Knots	
Course Over	309.62	Degrees	True
Ground			
Date	120598		Dummy
Magnetic variation		Degrees	E=east or W=west
Checksum	*10		
<CR><LF>			End of message termination

VTG-Course Over Ground and Ground Speed

Table 7 contains the values of the following example:

\$GPVTG, 309.62, T, M, 0.13, N, 0.2, K*6E

Table 7: VTG Data Format

Name	Example	Units	Description
Message ID	\$GPVTG		VTG protocol header
Course	309.62	Degrees	Measured heading
Reference	T		True
Course		Degrees	Measured heading
Reference	M		Magnetic
Speed	0.13	Knots	Measured horizontal speed
Units	N		Knots
Speed	0.2	Km/hr	Measured horizontal speed
Units	K		Kilometer per hour
Checksum	K		Kilometer per hour
Date	*6E		
<CR><LF>			End of message termination