

GPS/GNSS Antenna Module

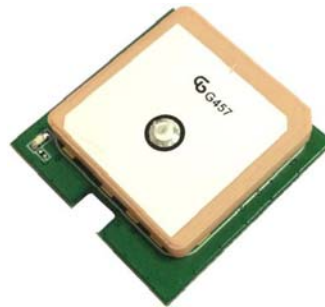

1. Product Information

1.1 Product Name: YIC93030PGMFR

1.2 Product Description:

YIC93030PGMFR is a RS232 interface, compact, high performance, and low power consumption flash base GPS/GNSS Antenna Module.

It uses the chipset which can track up to 56 channels at a time and perform fast TTFF in weak signal environments.

YIC93030PGMFR is suitable for the following applications:

- Automotive navigation
- Personal positioning
- Fleet management
- Mobile phone navigation
- Marine navigation

1.3 Product Features:

- 1PPS output
- High performance and low power consumption GPS Chipset
- Very high sensitivity
- Extremely fast TTFF (Time To First Fix) at low signal level
- Built-in SPI Flash
- Built-in LNA
- Compact size suitable for space-sensitive application
- Support NMEA 0183 and ublox binary protocol

1.4 Product Specifications

GPS Performance

| GPS Receiver | | |
|---|--|---|
| Chip | UBX-G7020 | |
| Frequency | GPS, GALILEO, QZSS: L1 1575.42MHz, C/A code or GLONASS: L1 1598.0625MHz ~ 1605.375MHz, C/A code | |
| Channels | Support 56 channels | |
| Update rate | 1Hz default, up to 10Hz | |
| Sensitivity | Tracking | -163dBm, up to -165dBm (with external LNA) |
| | Cold Start | -143.5dBm, up to -148dBm (with external LNA) |
| Acquisition Time | Hot start (Open Sky) | < 1s (typical) |
| | Hot start (Indoor) | < 30s |
| | Cold Start (Open Sky) | 32s (typical) without AGPS |
| < 15s (typical) with AGPS (hybrid ephemeris prediction) | | |
| Position Accuracy | Autonomous | 3m (2D RMS) |
| | SBAS | 2.5m (depends on accuracy of correction data) |
| Max. Altitude | 50,000m Max | |
| Max. Velocity | < 515 m/s | |
| Protocol Support | NMEA 0183 | 9600 bps, 8 data bits, no parity, 1 stop bits (default) |
| | | 1Hz: GGA, GLL, GSA, GSV, RMC, VTG |
| Physical Characteristic | | |
| Dimensions | 30.0mm * 30.0 mm * 8.4mm ±0.2mm | |

1.5 DC Electrical characteristics

| Parameter | Symbol | Conditions | Min. | Typ. | Max. | Units |
|------------------------------|--------|--|------|-------------------|--------------------|-------|
| Input Voltage | VCC | | 3.3 | 5.0 | 5.5 | V |
| Input Backup Battery Voltage | V_BCKP | | 2.8 | | 3.6 | V |
| Supply Current | Iss | VCC = 3.3V, w/o active antenna, Peak Acquisition Tracking Standby | | 37 | 150 ⁽¹⁾ | mA |
| | | | | 35 | | mA |
| | | | | 30 ⁽²⁾ | | mA |
| | | | | 550 | | uA |
| Backup Battery Current | Ibat | VCC = 0V | | 20 | | uA |
| High Level Input Voltage | VIH | | -3 | | -5 | V |
| Low Level Input Voltage | VIL | | 3 | | 5 | V |
| High Level Input Current | IIH | no pull-up or down | 1 | | 5 | uA |
| Low Level Input Current | IIL | no pull-up or down | 1 | | 2 | uA |
| High Level Output Voltage | VOH | | -3 | | -5 | V |
| Low Level Output Voltage | VOL | | 3 | | 5 | V |
| High Level Output Current | IOH | | 1 | | 3 | mA |
| Low Level Output Current | IOL | | 1 | | 3 | mA |

Note 1: This happens when downloading AGPS data to Module.

Note 2: Measured when position fix (1Hz) is available, input voltage is 3.3V and the function of self-generated ephemeris prediction is inactive.

1.6 Temperature characteristics

| Parameter | Symbol | Min. | Typ. | Max. | Units |
|-----------------------|--------|------|------|------|-------|
| Operating Temperature | Topr | -40 | 25 | 85 | °C |
| Storage Temperature | Tstg | -40 | 25 | 85 | °C |

2. Pin Assignments & Dimensions

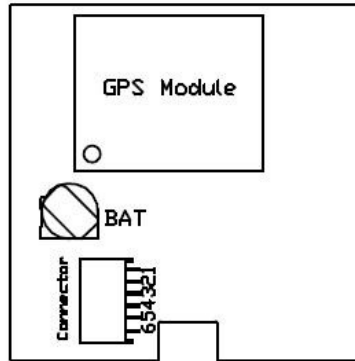

| Pin NO. | Pin Name | I/O | Remark |
|---------|----------|-----|--------------------------|
| 1. | VCC | I | Module Power Supply |
| 2. | AGND | G | Ground |
| 3. | GND | G | Ground |
| 4. | RXD | I | RS232 Serial Data Input |
| 5. | TXD | O | RS232 Serial Data Output |
| 6. | PPS | O | Time Pulse(1PPS) |

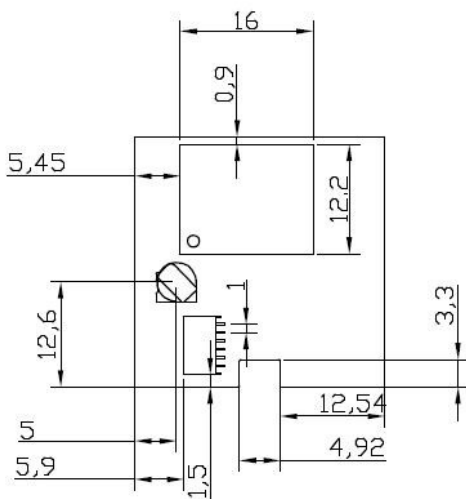

Front view

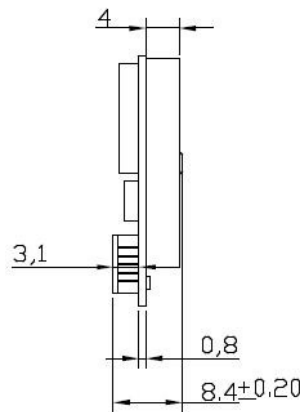

Profile view

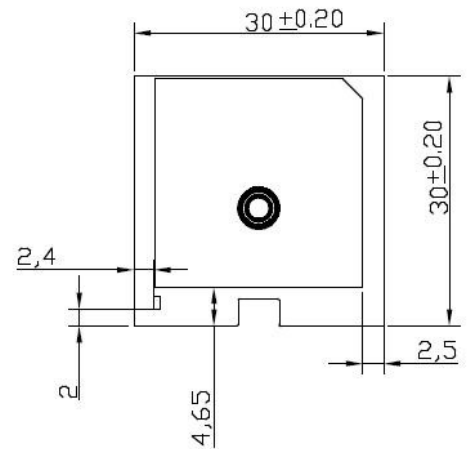

Rear view

3. Application Circuit : (Example)

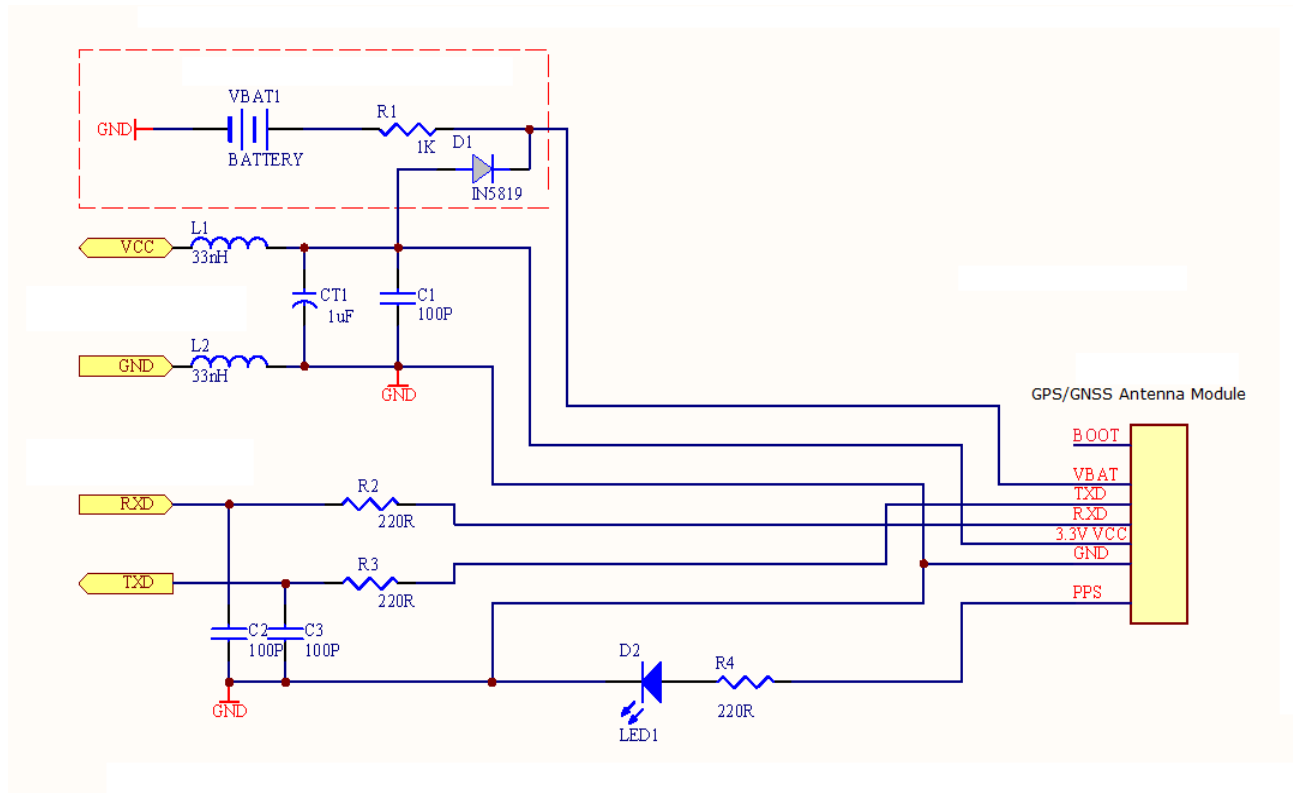

4. Software Protocol

NMEA output message

Table 4.1 NMEA output message

| NMEA | Description |
|------|--|
| GGA | Global positioning system fixed data |
| GLL | Geographic position - latitude/longitude |
| GSA | GNSS DOP and active satellites |
| GSV | GNSS satellites in view |
| RMC | Recommended minimum specific GNSS data |
| VTG | Course over ground and ground speed |

GGA--- Global Positioning System Fixed Data

Table 4.2 contains the values for the following example:

\$GPGGA,060406.000,2503.7148,N,12138.7451,E,2,17,0.71,116.7,M,15.3,M,0000,0000*6D

Table4. 2 GGA Data Format

| Name | Example | Units | Description |
|------------------------|------------|--------|-----------------------------------|
| Message ID | \$GPGGA | | GGA protocol header |
| UTC Time | 060406.000 | | hhmmss.sss |
| Latitude | 2503.7148 | | ddmm.mmmm |
| N/S indicator | N | | N=north or S=south |
| Longitude | 12138.7451 | | dddmm.mmmm |
| E/W Indicator | E | | E=east or W=west |
| Position Fix Indicator | 2 | | See Table 4.3 |
| Satellites Used | 17 | | Range 0 to 33 |
| HDOP | 0.71 | | Horizontal Dilution of Precision |
| MSL Altitude | 116.7 | mters | |
| Units | M | mters | |
| Geoid Separation | 15.3 | mters | |
| Units | M | mters | |
| Age of Diff. Corr. | 0000 | second | Null fields when DGPS is not used |
| Diff. Ref. Station ID | 0000 | | |
| Checksum | *6D | | |
| <CR> <LF> | | | End of message termination |

Table4.3 Position Fix Indicators

| Value | Description |
|-------|---------------------------------------|
| 0 | Fix not available or invalid |
| 1 | GPS SPS Mode, fix valid |
| 2 | Differential GPS, SPS Mode, fix valid |
| 3-5 | Not supported |
| 6 | Dead Reckoning Mode, fix valid |

GLL--- Geographic Position – Latitude/Longitude

Table4.4 contains the values for the following example:

\$GNGLL,2503.7148,N,12138.7451,E,060406.000,A,D*46

Table3.4 GLL Data Format

| Name | Example | Units | Description |
|---------------|------------|-------|--|
| Message ID | \$GNGLL | | GLL protocol header (GPGLL or GNGLL; GP indicates the device receives GPS satellites signal only and GN indicates the position is calculated with BEIDOU satellite signal) |
| Latitude | 2503.7148 | | ddmm.mmmm |
| N/S indicator | N | | N=north or S=south |
| Longitude | 12138.7451 | | dddmm.mmmm |
| E/W indicator | E | | E=east or W=west |
| UTC Time | 060406.000 | | hhmmss.sss |
| Status | A | | A=data valid or V=data not valid |
| Mode | D | | A=autonomous, D=DGPS, E=DR, N=Data not valid, R=Coarse Position, S=Simulator |
| Checksum | *46 | | |
| <CR> <LF> | | | End of message termination |

GSA---GNSS DOP and Active Satellites

Table 4.5 contains the values for the following example:

\$GNGSA,A,3,22,21,18,12,24,25,14,15,193,,,,,1.18,0.71,0.95*2C

\$GNGSA,A,3,205,207,210,202,201,203,209,208,,,,,1.18,0.71,0.95*1C

Table3. 5 GSA Data Format

| Name | Example | Units | Description |
|----------------------|---------|-------|--|
| Message ID | \$GNGSA | | GSA protocol header (GNGSA or GPGSA; GP indicates the device receives GPS satellites signal only and GN indicates the position is calculated with BEIDOU satellite signal).First row of GSA message contains GPS & QZSS satellites and second row of GSA message contains BEIDOU satellites. |
| Mode 1 | A | | See Table 4.6 |
| Mode 2 | 3 | | See Table 4.7 |
| ID of satellite used | 22 | | Sv on Channel 1 |
| ID of satellite used | 21 | | Sv on Channel 2 |
| | | | |
| ID of satellite used | | | Sv on Channel 12 |
| PDOP | 1.18 | | Position Dilution of Precision |
| HDOP | 0.71 | | Horizontal Dilution of Precision |
| VDOP | 0.95 | | Vertical Dilution of Precision |
| Checksum | *2C | | |
| <CR> <LF> | | | End of message termination |

Table 4.6 Mode 1

| Value | Description |
|-------|---|
| M | Manual- forced to operate in 2D or 3D mode |
| A | Automatic-allowed to automatically switch 2D/3D |

Table 4.7 Mode 2

| Value | Description |
|-------|-------------------|
| 1 | Fix not available |
| 2 | 2D |
| 3 | 3D |

GSV---GNSS Satellites in View

Table 4.8 contains the values for the following example:

\$GPGSV,6,1,21,18,78,169,36,209,72,273,36,22,63,309,38,207,63,328,38*7B

\$GPGSV,6,2,21,203,58,205,39,25,56,138,39,201,55,141,34,206,50,168,*45

\$GPGSV,6,3,21,210,49,282,34,12,48,076,39,204,39,118,,14,38,322,37*77

\$GPGSV,6,4,21,193,37,180,34,202,36,246,29,24,23,041,34,31,21,244,*71

\$GPGSV,6,5,21,21,17,198,33,205,16,258,28,15,12,092,33,208,09,169,30*7B

\$GPGSV,6,6,21,51,,,*7E

Table 4.8 GSV Data Format

| Name | Example | Units | Description |
|---------------------------------------|---------|---------|--|
| Message ID | \$GPGSV | | GSV protocol header |
| Total number of messages ¹ | 6 | | Range 1 to 6 |
| Message number ¹ | 1 | | Range 1 to 6 |
| Satellites in view | 21 | | |
| Satellite ID | 18 | | Channel 1 (Range 01 to 237), GPS Satellites ID : 01~32, SBAS Satellites ID : 33~64, QZSS Satellites ID:193~196, &BEIDOU Satellites ID : 201~214 |
| Elevation | 78 | degrees | Channel 1 (Range 00 to 90) |
| Azimuth | 169 | degrees | Channel 1 (Range 000 to 359) |
| SNR (C/No) | 36 | dB-Hz | Channel 1 (Range 00 to 99, null when not tracking) |
| Satellite ID | 207 | | Channel 4 (Range 01 to 237) , GPS Satellites ID : 01~32, SBAS Satellites ID : 33~64, QZSS Satellites ID:193~196, &BEIDOU Satellites ID : 201~214 |
| Elevation | 63 | degrees | Channel 4 (Range 00 to 90) |
| Azimuth | 328 | degrees | Channel 4 (Range 000 to 359) |
| SNR (C/No) | 38 | dB-Hz | Channel 4 (Range 00 to 99, null when not tracking) |
| Checksum | *7B | | |
| <CR> <LF> | | | End of message termination |

Depending on the number of satellites tracked multiple messages of GSV data may be required.

RMC---Recommended Minimum Specific GNSS Data

Table 4.9 contains the values for the following example:

\$GNRMC,060406.000,A,2503.7148,N,12138.7451,E,0.01,0.00,180313,,D*78

Table 4.9 RMC Data Format

| Name | Example | Units | Description |
|--------------------|------------|---------|--|
| Message ID | \$GNRMC | | RMC protocol header (GNRMC or GPRMC; GP indicates the device receives GPS satellites signal only and GN indicates the position is calculated with BEIDOU satellite signal) |
| UTC Time | 060406.000 | | hhmmss.sss |
| Status | A | | A=data valid or V=data not valid |
| Latitude | 2503.7148 | | ddmm.mmmm |
| N/S Indicator | N | | N=north or S=south |
| Longitude | 12138.7451 | | dddmm.mmmm |
| E/W Indicator | E | | E=east or W=west |
| Speed over ground | 0.01 | knots | True |
| Course over ground | 0.00 | degrees | |
| Date | 180313 | | ddmmyy |
| Magnetic variation | | degrees | |
| Variation sense | | | E=east or W=west (Not shown) |
| Mode | D | | A=autonomous, D=DGPS, E=DR, N=Data not valid, R=Coarse Position, S=Simulator |
| Checksum | *78 | | |
| <CR> <LF> | | | End of message termination |

VTG---Course Over Ground and Ground Speed

Table 4.10 contains the values for the following example:

\$GPVTG,0.00,T,,M,0.01,N,0.02,K,D*3B

Table 4.10 VTG Data Format

| Name | Example | Units | Description |
|--------------------|---------|---------|---|
| Message ID | \$GPVTG | | VTG protocol header |
| Course over ground | 0.00 | degrees | Measured heading |
| Reference | T | | True |
| Course over ground | | degrees | Measured heading |
| Reference | M | | Magnetic |
| Speed over ground | 0.01 | knots | Measured speed |
| Units | N | | Knots |
| Speed over ground | 0.02 | km/hr | Measured speed |
| Units | K | | Kilometer per hour |
| Mode | D | | A=autonomous, D=DGPS, E=DR, N=Data not valid,R=Coarse Position, S=Simulator |
| Checksum | *3B | | |
| <CR> <LF> | | | End of message termination |