

GPS & GLONASS Receiver (G-Mouse)

1. Product Information

- 1.1 Product Name :** GT-503GG (Adhesive Mount)
GT-503MGG (Magnetic Mount)



1.2 Product Description:

GT-503(M)GG is a compact, high performance, and low power consumption G-Mouse.

It uses the chipset of MediaTek which can track up to 56 channels at a time and perform fast TTFF in weak signal environments.

GT-503(M)GG is suitable for the following applications:

- Automotive navigation
- Personal positioning
- Fleet management
- Marine navigation

1.3 Product Features:

- High performance and low power consumption GNSS Chipset
- Very high sensitivity
- Extremely fast TTFF (Time To First Fix) at low signal level
- Chipset protocol
- LED display for GPS status
- Custom printed marking are available

1.4 Product Specifications

GNSS Performance

| GNSS Receiver | | |
|-------------------------|--|--|
| Chip | MediaTek | |
| Frequency | GPS, GALILEO, QZSS: L1 1575.42MHz, C/A code GLONASS L10F SBAS L1 C/A:WAAS, EGNOS, MSAS | |
| Channels | Support 99 channels (33 Tracking, 99 Acquisition) | |
| Update rate | 1Hz default, up to 10Hz | |
| Sensitivity | Tracking | -161dBm, up to -165dBm (with external LNA) |
| | Cold start | -142.5dBm, up to -148dBm (with external LNA) |
| Acquisition Time | Hot start (Open Sky) | < 1s |
| | Cold Start (Open Sky) | < 38s |
| | | < 18s with AGPS |
| Position Accuracy | Autonomous | 5m (2D RMS). |
| | SBAS | 2.5m (depends on accuracy of correction data). |
| Max. Altitude | < 18,000 m, up to 50,000m by request | |
| Max. Velocity | Velocity < 515 m/s | |
| Protocol Support | NMEA 0183 | 9600 bps, 8 data bits, no parity, 1 stop bits (default) 1Hz: GGA, GLL, GSA, GSV, RMC, VTG |
| Physical Characteristic | | |
| Dimensions | 55.0mm * 46.0 mm * 14.5mm ±0.2mm | |

1.5 DC Electrical characteristics

| Parameter | Symbol | Conditions | Min. | Typ. | Max. | Units |
|------------------------------|--------|--|------|-------------------|--------------------|-------|
| Input Voltage | VCC | | 2.8 | 3.3 | 5.5 | V |
| Input Backup Battery Voltage | V_BCKP | | 2.8 | | 3.6 | V |
| Supply Current | Iss | VCC = 3.3V, w/o active antenna, Peak Acquisition Tracking Standby | | 50 | 150 ⁽¹⁾ | mA |
| | | | | 50 | | mA |
| | | | | 45 ⁽²⁾ | | mA |
| | | | | 650 | | uA |
| Backup Battery Current | Ibat | VCC = 0V | | 12 | | uA |
| High Level Input Voltage | VIH | | 2.1 | | 3.0 | V |
| Low Level Input Voltage | VIL | | -0.3 | | 0.9 | V |
| High Level Input Current | IIH | no pull-up or down | -1 | | 1 | uA |
| Low Level Input Current | IIL | no pull-up or down | -1 | | 1 | uA |
| High Level Output Voltage | VOH | | 2.1 | | 3.0 | V |
| Low Level Output Voltage | VOL | | - | | 1.2 | V |
| High Level Output Current | IOH | | 1 | | 3 | mA |
| Low Level Output Current | IOL | | 1 | | 3 | mA |

Note 1: This happens when downloading AGPS data to Module.

Note 2: Measured when position fix (1Hz) is available, input voltage is 3.3V and the function of self-generated ephemeris prediction is inactive.

Temperature characteristics

| Parameter | Symbol | Min. | Typ. | Max. | Units |
|-----------------------|--------|------|------|------|-------|
| Operating Temperature | Topr | -40 | 25 | 85 | °C |
| Storage Temperature | Tstg | -40 | 25 | 85 | °C |

2. Physical Dimension

(Different cables & connectors can be specified according to requirements)

| P/N | Mount | Description |
|---------------|----------|-------------------------|
| GT-503GG-MX4 | Adhesive | (4 Pin Molex Connector) |
| GT-503MGG-MX4 | Magnetic | (4 Pin Molex Connector) |

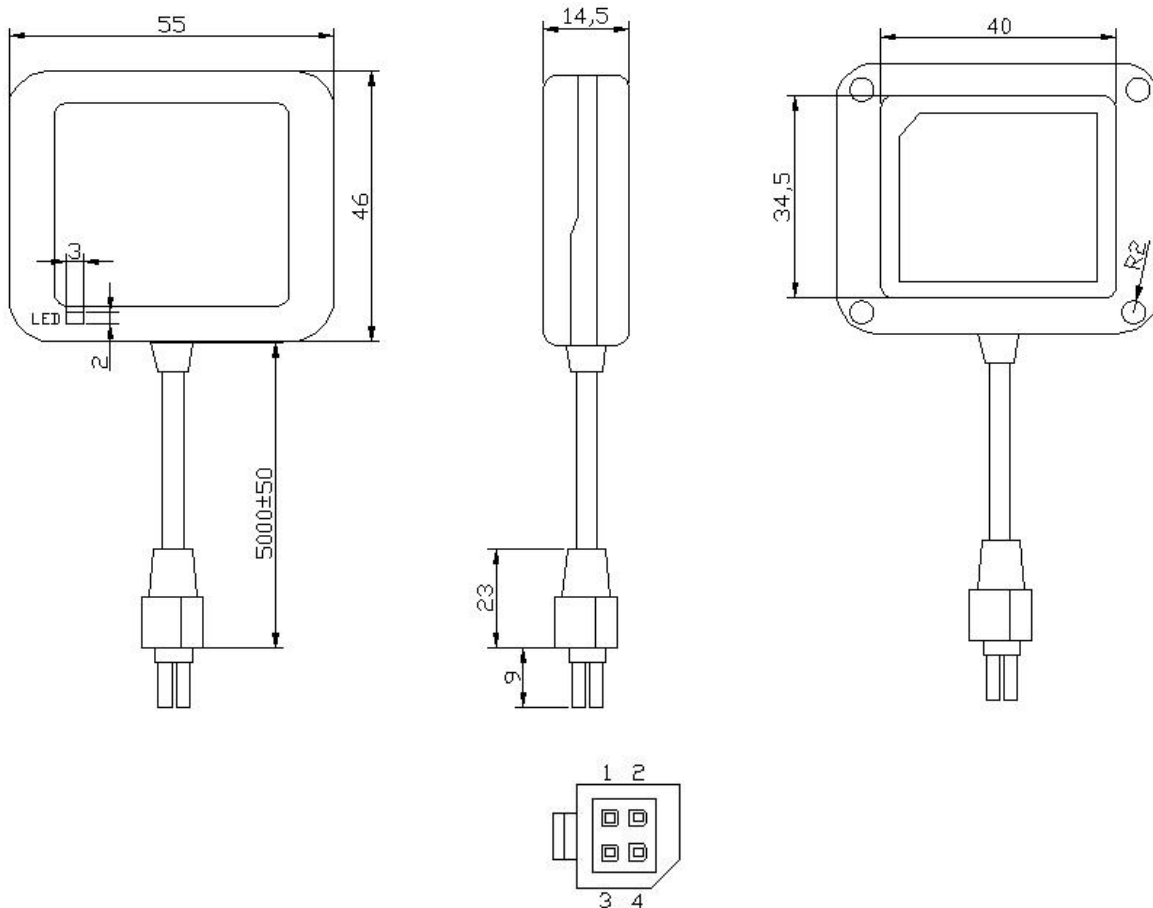

| I/O Interface | Voltage level |
|-----------------------|-----------------|
| 4 pin Molex Connector | UART(TTL level) |

| Pin | Pin define | Level |
|-----|------------|---|
| 1 | Vcc | 3.0—5.0V DC |
| 2 | GND | Ground |
| 3 | TXD | TTL output |
| 4 | RXD | TTL Input |
| LED | GPS Status | Blinking Once : Power on LED Blinking : Position fixed |

3. NMEA 0183 Protocol

The NMEA protocol is an ASCII-based protocol, Records start with a \$ and with carriage return/line feed. GPS specific messages all start with \$GPxxx where xxx is a three-letter identifier of the message data that follows. NMEA messages have a checksum, which allows detection of corrupted data transfers.

GT-503(M)GG support the following NMEA-0183 messages: GGA, GLL, GSA, GSV, RMC and VTG.

Table 1: NMEA-0183 Output Messages

| NMEA | Description |
|------|--|
| GGA | Global positioning system fixed data |
| GLL | Geographic position - latitude/longitude |
| GSA | GNSS DOP and active satellites |
| GSV | GNSS satellites in view |
| RMC | Recommended minimum specific GNSS data |
| VTG | Course over ground and ground speed |

GGA-Global Positioning System Fixed Data

Table 2 contains the values of the following example:

\$GPGGA, 161229.487,3723.24751,N, 12158.34160,W, 1,07,1.0,9.0,M.0000*18

Table 2: GGA Data Format

| Name | Example | Units | Description |
|-----------------------|-------------|--------|-----------------------------------|
| Message ID | \$GPGGA | | GGA protocol header |
| UTC Position | 161229.487 | | hhmmss.sss |
| Latitude | 3723.24571 | | ddmm.mmmmm |
| N/S indicator | N | | N=north or S=south |
| Longitude | 12158.34160 | | ddmm.mmmmm |
| E/W Indicator | W | | E=east orW=west |
| Position FixIndicator | 1 | | See Table 2-1 |
| Satellites Used | 07 | | Range 0 to 12 |
| HDOP | 1.0 | | Horizontal Dilution of Precision |
| MSLAltitude | 9.0 | meters | |
| Units | M | meters | |
| Geoids Separation | | meters | |
| Units | M | meters | |
| Age of Diff.Corr. | | second | Null fields when DGPS is not Used |
| Diff.Ref.Station ID | 0000 | | |
| Checksum | *18 | | |
| <CR><LF> | | | End of message termination |

Table 2-1: Position Fix Indicators

| Value | Description |
|-------|---------------------------------------|
| 0 | Fix not available or invalid |
| 1 | GPS SPS Mode, fix valid |
| 2 | Differential GPS, SPS Mode, fix valid |
| 3 | GPS PPS Mode, fix valid |

GLL-Geographic Position – Latitude/Longitude

Table 3 contains the values of the following example:

\$GPGLL , 3723.24755, N,12158.34161,W,161229.487, A*2C.

Table 3: GLL Data Format

| Name | Example | Units | Description |
|---------------|-------------|-------|----------------------------------|
| Message ID | \$GPGLL | | GLL protocol header |
| Latitude | 3723.24755 | | Ddmm.mmmmm |
| N/S Indicator | N | | N=north or S=south |
| Longitude | 12158.34161 | | ddmm.mmmmm |
| E/W Indicator | W | | E=east or W=west |
| UTC Position | 161229.487 | | Hhmmss.sss |
| Status | A | | A=data valid or V=data not valid |
| Checksum | *2C | | |
| <CR><LF> | | | End of message termination |

GSA-GNSS DOP and Active Satellites

Table 4 contains the values of the following example:

\$GPGSA , A, 3, 07, 02, 26,27, 09, 04,15, , , , , , 1.8,1.0,1.5*33.

Table 4: GSA Data Format

| Name | Example | Units | Description |
|----------------|---------|-------|----------------------------------|
| Message ID | \$GPGSA | | GSA protocol header |
| Mode 1 | A | | See Table 4-1 |
| Mode 2 | 3 | | See Table 4-2 |
| Satellite Used | 07 | | Sv on Channel 1 |
| Satellite Used | 02 | | Sv on Channel 2 |
| ... | ... | | ... |
| Satellite Used | | | Sv on Channel 12 |
| PDOP | 1.8 | | Position Dilution of Precision |
| HDOP | 1.0 | | Horizontal Dilution of Precision |
| VDOP | 1.5 | | Vertical Dilution of Precision |
| Checksum | *33 | | |
| <CR><LF> | | | End of message termination |

Table 4-1: Mode 1

| Value | Description |
|-------|-------------------|
| 1 | Fix not available |
| 2 | 2D |
| 3 | 3D |

Table 4-2: Mode 2

| Value | Description |
|-------|---|
| M | Manual-forced to operate in 2D or 3D mode |
| A | Automatic-allowed to automatically switch 2D/3D |

GSV-GNSS Satellites in View

Table 5 contains the values of the following example:

\$GPGSV , 2, 1, 07, 07, 79,048, 42, 02, 51,062, 43, 26, 36,256, 42, 27, 27, 138,42*71

\$GPGSV, 2, 2, 07, 09, 23,313, 42, 04, 19, 159, 41, 15,12,041, 42*41.

Table 5: GGA Data Format

| Name | Example | Units | Description |
|--------------------|---------|---------|---------------------------------------|
| Message ID | \$GPGSV | | GSV protocol header |
| Number of Message | 2 | | Range 1 to 3 |
| Message Number | 1 | | Range 1 to 3 |
| Satellites in View | 07 | | |
| Satellite ID | 07 | | Channel 1(Range 1 to 32) |
| Elevation | 79 | degrees | Channel 1(Maximum 90) |
| Azimuth | 048 | degrees | Channel 1(True, Range 0 to 359) |
| SNR(C/NO) | 42 | dBHz | Range 0 to 99,null when not tracking |
| ... | | | ... |
| Satellite ID | 27 | | Channel 4(Range 1 to 32) |
| Elevation | 27 | degrees | Channel 4(Maximum 90) |
| Azimuth | 138 | degrees | Channel 4(True, Range 0 to 359) |
| SNR(C/NO) | 42 | dBHz | Range 0 to 99, null when not tracking |
| Checksum | *71 | | |
| <CR><LF> | | | End of message termination |

Depending on the number of satellites tracked multiple messages of GSV data may be required

RMC-Recommended Minimum Specific GNSS Data

Table 6 contains the values of the following example:

\$GPRMC, 161229.487, A, 3723.24751, N, 12158.34161, W, 0.13, 309.62, 120598,, *10

Table 6: RMC Data Format

| Name | Example | Units | Description |
|--------------------|-------------|---------|----------------------------------|
| Message ID | \$GPRMC | | RMC protocol header |
| UTS Position | 161229.487 | | hhmmss.sss |
| Status | A | | A=data valid or V=data not valid |
| Latitude | 3723.24751 | | ddmm.mmmmm |
| N/S Indicator | N | | N=north or S=south |
| Longitude | 12158.34161 | | Ddmm.mmmmm |
| E/W Indicator | W | | E=east or W=west |
| Speed Over Ground | 0.13 | Knots | |
| Course Over | 309.62 | Degrees | True |
| Ground | | | |
| Date | 120598 | | Dummy |
| Magnetic variation | | Degrees | E=east or W=west |
| Checksum | *10 | | |
| <CR><LF> | | | End of message termination |

VTG-Course Over Ground and Ground Speed

Table 7 contains the values of the following example:

\$GPVTG, 309.62, T, M, 0.13, N, 0.2, K*6E

Table 7: VTG Data Format

| Name | Example | Units | Description |
|------------|---------|---------|----------------------------|
| Message ID | \$GPVTG | | VTG protocol header |
| Course | 309.62 | Degrees | Measured heading |
| Reference | T | | True |
| Course | | Degrees | Measured heading |
| Reference | M | | Magnetic |
| Speed | 0.13 | Knots | Measured horizontal speed |
| Units | N | | Knots |
| Speed | 0.2 | Km/hr | Measured horizontal speed |
| Units | K | | Kilometer per hour |
| Checksum | K | | Kilometer per hour |
| Date | *6E | | |
| <CR><LF> | | | End of message termination |