

# YIC



## GPS & GLONASS Antenna Module YIC53026GMGG-33

**Datasheet**

[www.yic.com.tw](http://www.yic.com.tw)

## 1. Product Information

### 1.1 Product Description

YIC53026MGG-33 is a compact, high performance, and low power consumption GNSS Antenna Module.

It uses the chipset which can track up to 99 channels at a time and perform fast TTFF in weak signal environments.

YIC53026MGG-33 is suitable for the following applications

- Automotive navigation
- Personal positioning
- Fleet management
- Mobile phone navigation
- Marine navigation

### 1.2 Product Features

- MediaTek high sensitivity solution
- Support 99-channel (33 Tracking, 99 Acquisition)
- Ultra low power consumption
- Fast TTFF at low signal level
- Built-in 12 multi-tone active interference canceller
- Free hybrid ephemeris prediction to achieve faster cold start
- Built-in data logger
- Built-in DC/DC converter to save power
- Up to 10 Hz update rate
- $\pm 11$ ns high accuracy time pulse (1PPS)
- Capable of SBAS (WAAS, EGNOS, MSAS, GAGAN)
- Support Japan QZSS
- Indoor and outdoor multi-path detection and compensation
- RoHS compliant

## 1.3 Product Specifications

GNSS Receiver		
Chip	MediaTek	
Frequency	GPS, GALILEO, QZSS: L1 1575.42MHz, C/A code GLONASS: L1 1598.0625MHz ~ 1605.375MHz, C/A code	
Channels	Support 99 channels (33 Tracking, 99 Acquisition)	
Update rate	1Hz default, up to 10Hz	
Sensitivity	Tracking	-161dBm, up to -165dBm (with external LNA)
	Cold start	-142.5dBm, up to -148dBm (with external LNA)
Acquisition Time	Hot start (Open Sky)	< 1s
	Cold Start (Open Sky)	< 38s
		< 18s with AGPS
Position Accuracy	Autonomous	5m (2D RMS).
	SBAS	2.5m (depends on accuracy of correction data).
Max. Altitude	< 18,000 m, up to 50,000m by request	
Max. Velocity	Velocity < 515 m/s	
Protocol Support	NMEA 0183	9600 bps, 8 data bits, no parity, 1 stop bits (default) 1Hz: GGA, GLL, GSA, GSV, RMC, VTG
Physical Characteristic		
Dimensions	30.2mm * 26.2 mm * 8.0mm ±0.2mm	

## 1.4 DC Electrical Characteristics

Parameter	Symbol	Conditions	Min.	Typ.	Max.	Units
Input Voltage	VCC		3.0	3.3	5.5	V
Input Backup Battery Voltage	V_BCKP		2.0		4.3	V
Supply Current	Iss	VCC = 3.3V			150 <sup>(1)</sup>	mA
		Peak Acquisition		31		mA
		Tracking		24 <sup>(2)</sup>		mA
		Standby		600		uA
Backup Battery Current	Ibat	VCC = 0V		7		uA
High Level Input Voltage	VIH		2.0		3.6	V
Low Level Input Voltage	VIL		-0.3		0.8	V
High Level Input Current	IIH	no pull-up or down	-1		1	uA
Low Level Input Current	IIL	no pull-up or down	-1		1	uA
High Level Output Voltage	VOH		2.4		3.3	V
Low Level Output Voltage	VOL				0.4	V
High Level Output Current	IOH			2		mA
Low Level Output Current	IOL			2		mA

**Note 1:** This happens when downloading AGPS data to Module.

**Note 2:** Measured when position fix (1Hz) is available, input voltage is 3.3V and the function of self-generated ephemeris prediction is inactive.

### Temperature characteristics

Parameter	Symbol	Min.	Typ.	Max.	Units
Operating Temperature	Topr	-40	25	85	°C
Storage Temperature	Tstg	-40	25	85	°C

## 2. Technical Information

### 2.1 Module Pin Assignment

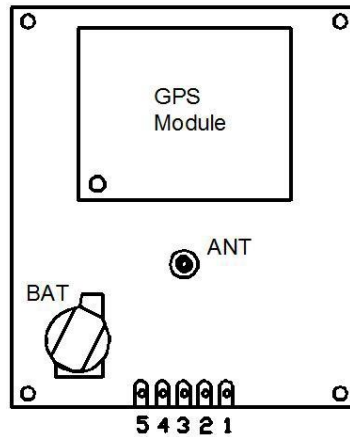

Pin NO.	Pin Name	I/O	Remark
1.	GND	G	Ground
2.	VCC	I	Module Power Supply
3.	VBAT	I	RTC Battery Input
4.	RXD	I	UART/TTL Serial Data Input
5.	TXD	O	UART/TTL Serial Data Output

### 2.2 Dimensions

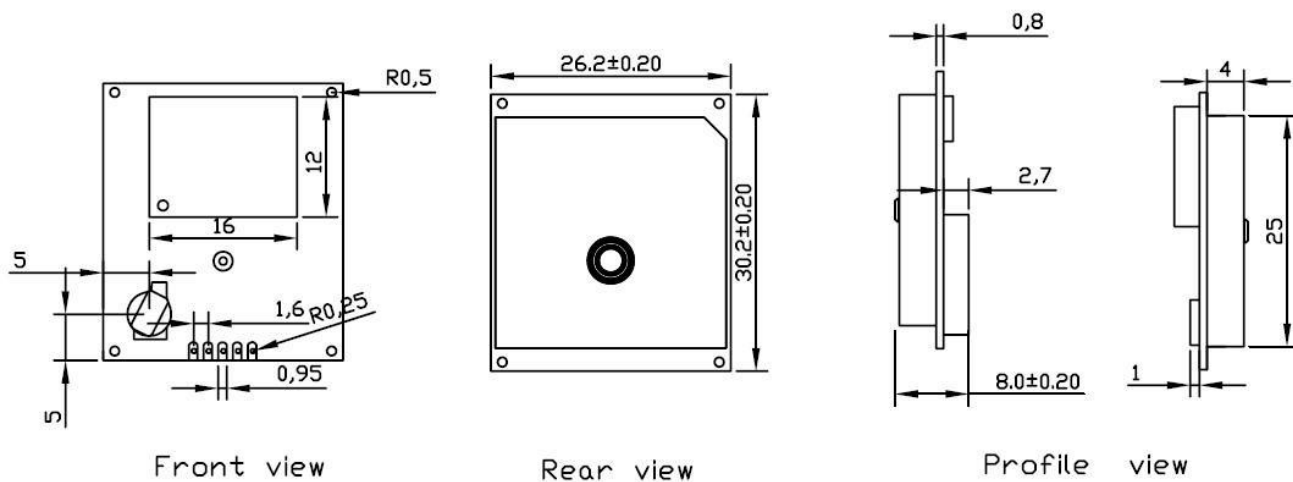

## 3. Application Circuit : (Example)

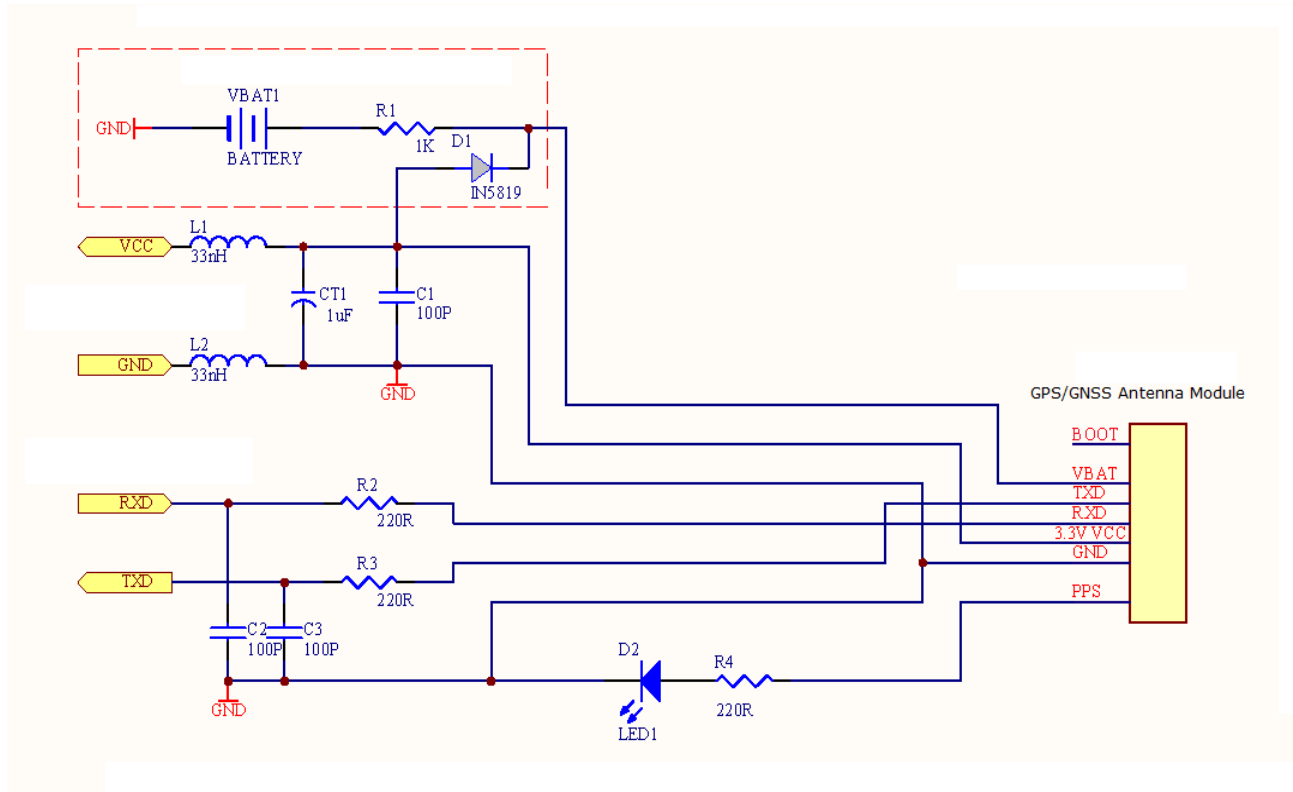

## 4. Software Protocol

NMEA output message

Table 4.1 NMEA output message

NMEA	Description
GGA	Global positioning system fixed data
GLL	Geographic position - latitude/longitude
GSA	GNSS DOP and active satellites
GSV	GNSS satellites in view
RMC	Recommended minimum specific GNSS data
VTG	Course over ground and ground speed

## GGA--- Global Positioning System Fixed Data

Table 4.2 contains the values for the following example:

```
$GPGGA,060406.000,2503.7148,N,12138.7451,E,2,17,0.71,116.7,M,15.3,M,0000,0000*6D
```

Table4. 2 GGA Data Format

Name	Example	Units	Description
Message ID	\$GPGGA		GGA protocol header
UTC Time	060406.000		hhmmss.sss
Latitude	2503.7148		ddmm.mmmm
N/S indicator	N		N=north or S=south
Longitude	12138.7451		dddmm.mmmm
E/W Indicator	E		E=east or W=west
Position Fix Indicator	2		See Table 4.3
Satellites Used	17		Range 0 to 33
HDOP	0.71		Horizontal Dilution of Precision
MSL Altitude	116.7	mters	
Units	M	mters	
Geoid Separation	15.3	mters	
Units	M	mters	
Age of Diff. Corr.	0000	second	Null fields when DGPS is not used
Diff. Ref. Station ID	0000		
Checksum	*6D		
<CR> <LF>			End of message termination

Table4.3 Position Fix Indicators

Value	Description
0	Fix not available or invalid
1	GPS SPS Mode, fix valid
2	Differential GPS, SPS Mode, fix valid
3-5	Not supported
6	Dead Reckoning Mode, fix valid



## GLL--- Geographic Position – Latitude/Longitude

Table4.4 contains the values for the following example:

\$GNGLL,2503.7148,N,12138.7451,E,060406.000,A,D\*46

Table3.4 GLL Data Format

Name	Example	Units	Description
Message ID	\$GNGLL		GLL protocol header (GPGLL or GNGLL; GP indicates the device receives GPS satellites signal only and GN indicates the position is calculated with BEIDOU satellite signal)
Latitude	2503.7148		ddmm.mmmm
N/S indicator	N		N=north or S=south
Longitude	12138.7451		dddmm.mmmm
E/W indicator	E		E=east or W=west
UTC Time	060406.000		hhmmss.sss
Status	A		A=data valid or V=data not valid
Mode	D		A=autonomous, D=DGPS, E=DR, N=Data not valid, R=Coarse Position, S=Simulator
Checksum	*46		
<CR> <LF>			End of message termination

## GSA---GNSS DOP and Active Satellites

Table 4.5 contains the values for the following example:

\$GNGSA,A,3,22,21,18,12,24,25,14,15,193,,,,,1.18,0.71,0.95\*2C

\$GNGSA,A,3,205,207,210,202,201,203,209,208,,,,,1.18,0.71,0.95\*1C

Table3. 5 GSA Data Format

Name	Example	Units	Description
Message ID	\$GNGSA		GSA protocol header (GNGSA or GPGSA; GP indicates the device receives GPS satellites signal only and GN indicates the position is calculated with BEIDOU satellite signal).First row of GSA message contains GPS & QZSS satellites and second row of GSA message contains BEIDOU satellites.
Mode 1	A		See Table 4.6
Mode 2	3		See Table 4.7
ID of satellite used	22		Sv on Channel 1
ID of satellite used	21		Sv on Channel 2
....			....
ID of satellite used			Sv on Channel 12
PDOP	1.18		Position Dilution of Precision
HDOP	0.71		Horizontal Dilution of Precision
VDOP	0.95		Vertical Dilution of Precision
Checksum	*2C		
<CR> <LF>			End of message termination

Table 4.6 Mode 1

Value	Description
M	Manual- forced to operate in 2D or 3D mode
A	Automatic-allowed to automatically switch 2D/3D

Table 4.7 Mode 2

Value	Description
1	Fix not available
2	2D
3	3D

## GSV---GNSS Satellites in View

Table 4.8 contains the values for the following example:

\$GPGSV,6,1,21,18,78,169,36,209,72,273,36,22,63,309,38,207,63,328,38\*7B

\$GPGSV,6,2,21,203,58,205,39,25,56,138,39,201,55,141,34,206,50,168,\*45

\$GPGSV,6,3,21,210,49,282,34,12,48,076,39,204,39,118,,14,38,322,37\*77

\$GPGSV,6,4,21,193,37,180,34,202,36,246,29,24,23,041,34,31,21,244,\*71

\$GPGSV,6,5,21,21,17,198,33,205,16,258,28,15,12,092,33,208,09,169,30\*7B

\$GPGSV,6,6,21,51,,,\*7E

Table 4.8 GSV Data Format

Name	Example	Units	Description
Message ID	\$GPGSV		GSV protocol header
Total number of messages <sup>1</sup>	6		Range 1 to 6
Message number <sup>1</sup>	1		Range 1 to 6
Satellites in view	21		
Satellite ID	18		Channel 1 (Range 01 to 237), GPS Satellites ID : 01~32, SBAS Satellites ID : 33~64, QZSS Satellites ID:193~196, &BEIDOU Satellites ID : 201~214
Elevation	78	degrees	Channel 1 (Range 00 to 90)
Azimuth	169	degrees	Channel 1 (Range 000 to 359)
SNR (C/No)	36	dB-Hz	Channel 1 (Range 00 to 99, null when not tracking)
Satellite ID	207		Channel 4 (Range 01 to 237) , GPS Satellites ID : 01~32, SBAS Satellites ID : 33~64, QZSS Satellites ID:193~196, &BEIDOU Satellites ID : 201~214
Elevation	63	degrees	Channel 4 (Range 00 to 90)
Azimuth	328	degrees	Channel 4 (Range 000 to 359)
SNR (C/No)	38	dB-Hz	Channel 4 (Range 00 to 99, null when not tracking)
Checksum	*7B		
<CR> <LF>			End of message termination

Depending on the number of satellites tracked multiple messages of GSV data may be required.

## RMC---Recommended Minimum Specific GNSS Data

Table 4.9 contains the values for the following example:

\$GNRMC,060406.000,A,2503.7148,N,12138.7451,E,0.01,0.00,180313,,,D\*78

Table 4.9 RMC Data Format

Name	Example	Units	Description
Message ID	\$GNRMC		RMC protocol header (GNRMC or GPRMC; GP indicates the device receives GPS satellites signal only and GN indicates the position is calculated with BEIDOU satellite signal)
UTC Time	060406.000		hhmmss.sss
Status	A		A=data valid or V=data not valid
Latitude	2503.7148		ddmm.mmmm
N/S Indicator	N		N=north or S=south
Longitude	12138.7451		dddmm.mmmm
E/W Indicator	E		E=east or W=west
Speed over ground	0.01	knots	True
Course over ground	0.00	degrees	
Date	180313		ddmmyy
Magnetic variation		degrees	
Variation sense			E=east or W=west (Not shown)
Mode	D		A=autonomous, D=DGPS, E=DR, N=Data not valid, R=Coarse Position, S=Simulator
Checksum	*78		
<CR> <LF>			End of message termination

## VTG---Course Over Ground and Ground Speed

Table 4.10 contains the values for the following example:

\$GPVTG,0.00,T,,M,0.01,N,0.02,K,D\*3B

Table 4.10 VTG Data Format

Name	Example	Units	Description
Message ID	\$GPVTG		VTG protocol header
Course over ground	0.00	degrees	Measured heading
Reference	T		True
Course over ground		degrees	Measured heading
Reference	M		Magnetic
Speed over ground	0.01	knots	Measured speed
Units	N		Knots
Speed over ground	0.02	km/hr	Measured speed
Units	K		Kilometer per hour
Mode	D		A=autonomous, D=DGPS, E=DR, N=Data not valid, R=Coarse Position, S=Simulator
Checksum	*3B		
<CR> <LF>			End of message termination