

# YIC



## Ultra Low Power & Multi-Constellation GNSS Module YIC51612EBGGB

**Datasheet**

[www.yic.com.tw](http://www.yic.com.tw)

## Revision History

| Date       | Reversion | Description                         |
|------------|-----------|-------------------------------------|
| 2022/11/15 | 1.0       | First Draft, Based on YIC51612EBGGB |
| 2024/04/20 | 2.0       | Add Design Note                     |
|            |           |                                     |

## Directory

|   |    |
|---|----|
| <b>Revision History</b> .....   | 2  |
| <b>1. Product Information</b> .....   | 5  |
| 1.1 Product Description .....   | 5  |
| 1.2 Product Features .....  | 6  |
| 1.3 Product Specifications .....  | 7  |
| 1.4 DC Electrical Characteristics .....   | 8  |
| <b>2. Block Diagram</b> .....   | 9  |
| <b>3. Module Pin Assignment</b> .....   | 10 |
| 3.1 Pin Descriptions .....  | 11 |
| 3.2 UART Interface .....  | 12 |
| 3.3 Inter-Integrated Circuit (I2C) Interface: .....                                 | 14 |
| 3.4 Evaluation Kit (YIC EVK-1612EB) .....   | 15 |
| <b>4. Antenna Consideration</b> .....   | 16 |
| 4.1 Recommended Antenna .....   | 17 |
| <b>5. Power Supply Requirement</b> .....  | 19 |
| <b>6. Backup Supply</b> .....   | 19 |
| <b>7. 1PPS Output</b> .....   | 19 |
| <b>8. PCB Layout Guidelines</b> .....   | 20 |
| 8.1 Separate RF and digital circuits into different PCB regions. ....               | 20 |
| 8.2 Antenna Placement on PCB Design Guide (If the design uses patch antenna ) ..... | 22 |
| 8.3 External Active Antenna Circuit .....   | 27 |
| <b>9. Application Circuit</b> .....   | 29 |
| <b>10. ESD handling precautions and Reliability</b> .....                           | 30 |
| 10.1 Electrostatic Discharge .....  | 30 |
| <b>11. Mechanical Dimensions</b> .....  | 32 |
| <b>12. Manufacturing, Packaging and Ordering Information</b> .....                  | 34 |
| 12.1. Assembly and Soldering .....  | 34 |
| 12.2. Moisture Sensitivity .....  | 35 |
| 12.3 Tape and Reel Packaging .....  | 35 |
| <b>13. Software Protocol</b> .....  | 36 |
| 13.1 GGA – Global Positioning System Fix Data .....                                 | 37 |
| 13.2 GLL – Latitude/Longitude .....   | 38 |
| 13.3 GSA – GNSS DOP and Active Satellites .....                                     | 39 |
| 13.4 GSV – GNSS Satellites in View .....  | 40 |
| 13.5 RMC – Recommended Minimum Specific GNSS Data .....                             | 41 |

---

|  |           |
|--|-----------|
| 13.6 VTG – Course Over Ground and Ground Speed ..... | 42        |
| 13.7 ZDA – TIME AND DATE .....                       | 43        |
| <b>14. Appendix References .....</b>                 | <b>44</b> |

## 1. Product Information

### 1.1 Product Description

The YIC51612EBGGB is a Multi-Constellation receiving module that supports single-band and multi-mode. It has built-in highly integrated GNSS receiver chip, supports multi band and multi system cm4f (main frequency 428MHz, 22nm Technology) chip of Third-generation BeiDou Navigation Satellite System (BDS-3). Besides, it is capable of tracking all global civil navigation systems ( GPS,QZSS, GLONASS, BDS, Galileo and SBAS) in all bands.

YIC51612EBGGB module is based on the state of art CYNOSURE III architecture, integrating single-band and multi-system GNSS RF and baseband. This newly designed architecture makes this single chip achieve sub-meter level position accuracy without correction data from ground-based augmentation station and higher sensitivity, greater for improved jam resistance and multipath, provide a highly robust service in complicated environment.

YIC51612EBGGB module contains MediaTek positioning engine inside, featuring high sensitivity, ultra low power consumption, and fast TTFF. The superior cold start sensitivity allows it to acquire, track, and get position fix autonomously in difficult weak signal environment. The receiver's superior tracking sensitivity allows continuous position coverage in nearly all outdoor application environments. The high performance signal parameter search engine is capable of testing 16 million time-frequency hypotheses per second, offering superior signal acquisition and TTFF speed.

### Applications

- Automotive Navigation
- Personal Positioning
- Fleet Management
- Marine Navigation
- Mobile phone Navigation
- Wearable and Portable

## 1.2 Product Features

- Build on high performance, low-power MediaTek chip set
- Ultra high track sensitivity: -165dBm
- Multi-Constellation reception of single-band and multi-systemsatellite signals
- Supports all civil GNSS signals
- Supports BDS-3 signal
- Extremely fast TTFF at low signal level(Cold start  $\leq 24s$ , Hot start  $\leq 1s$ ).
- Multipath detection and suppression
- Works with passive and active antenna
- Ultra low power consumption: 12 mA@3.3V
- NMEA-0183 compliant protocol or custom protocol
- Operating voltage:2.8V to 3.6V
- SMD type with stamp holes
- Small form factor: 16x12x2.6mm
- Operating temperature -40 ~ +85°C
- RoHS compliant (Lead-free)

## 1.3 Product Specifications

| GPS Receiver             |  |                                 |
|--------------------------|--|---------------------------------|
| Chip                     | GNSS engine has 47SVs channels and DSP accelerators  |                                 |
| GNSS Reception           | GPS/QZSS   | L1 C/A, L1C                     |
|                          | BeiDou   | B1I                             |
|                          | GLONASS  | L1                              |
|                          | Galileo  | E1                              |
|                          | SBAS   | WAAS, EGNOS, MSAS, GAGAN        |
| Update Rate              | GNSS   | 1Hz (10Hz on request)           |
| Position Accuracy        | GNSS   | 1.5m CEP                        |
|                          | SBAS   | 1.5m CEP                        |
| Velocity & Time Accuracy | GNSS   | 0.01m/s CEP                     |
|                          | SBAS   | 0.05 m/s                        |
|                          | 1PPS   | 25 ns                           |
| Accuracy Time            | Hot start  | 1 sec                           |
|                          | Cold start   | 24 sec                          |
| Sensitivity              | Cold start   | -148dBm                         |
|                          | Hot start  | -155dBm                         |
|                          | Tracking & navigation  | -165dBm                         |
|                          | Reacquisition  | -158dBm                         |
| GNSS Operating limit     | Velocity   | 515m/s                          |
|                          | Altitude   | 18,000m                         |
| Datum                    | Default WGS-84, User definable   |                                 |
| Protocol Support         | UART Port: TXD and RXD<br>115200bps (default), Supports baud rate 9600bps to 921600bps<br>NMEA 0183 Protocol Ver. 4.00/4.10, Cynosure GNSS Receiver Protocol |                                 |
| Environment              | Operation temperature  | -40°C ~ +85°C                   |
|                          | Storage temperature  | -55°C ~ +100°C                  |
|                          | Humidity   | 5% ~ 95%                        |
| Physical Characteristics | Size   | 16±0.15 × 12.2±0.15 × 2.6±0.1mm |
|                          | Weight   | Approx. 1g                      |

## 1.4 DC Electrical Characteristics

| Parameter  | Min. | Typ. | Max. | Units |
|--|------|------|------|-------|
| Input Voltage  | 2.8  | 3.3  | 3.6  | Volt  |
| Power Supplier Current                               |      |      |      |       |
| Acquisition Current (exclude active antenna current) |      | 12   |      | mA    |
| Tracking Current (exclude active antenna current)    |      | 12   |      | mA    |
| UART Port & I/O port Working Voltage                 |      |      |      |       |
| Low Level Output Voltage (VOL)                       |      |      | 0.4  | Volt  |
| High Level Output Voltage (VOH)                      | 2.4  |      |      | Volt  |
| Low Level Input Voltage (VIL)                        | 0.3  |      | 0.7  | Volt  |
| High Level Input Voltage (VIH)                       | 2.1  |      | 3.6  | Volt  |
| Low Level Input Current (IIL)                        | -10  |      | 10   | uA    |
| High Level Output Current (IIH)                      | -10  |      | 10   | uA    |
| RF Input Impedance (RFIN)                            |      | 50   |      | Ohm   |

## Absolute Maximum Ratings

| Parameter            | Minimum | Maximum | Condition |
|----------------------|---------|---------|-----------|
| Supply Voltage       | -0.5    | 3.6     | Volt      |
| Input Pin Voltage    | -0.5    | VCC+0.5 | Volt      |
| Input Power at RF_IN |         | 20      | dBm       |
| Storage Temperature  | -55     | 100     | degC      |



## 2. Block Diagram

The YIC51612EBGGB is a high performance (GPS, QZSS, GLONASS, BDS, Galileo and SBAS) in all bands . satellite navigation receiver in a compact surface mount package. It is based on the MediaTek positioning technology, providing high performance signal acquisition and tracking. The simple UART serial interface and the standard NMEA-0183 protocol make usage of YIC51612EBGGB very easy and straight forward.

The YIC51612EBGGB module performs all the necessary system initialization, signal acquisition, signal tracking, data demodulation, and calculation of navigation solution autonomously.

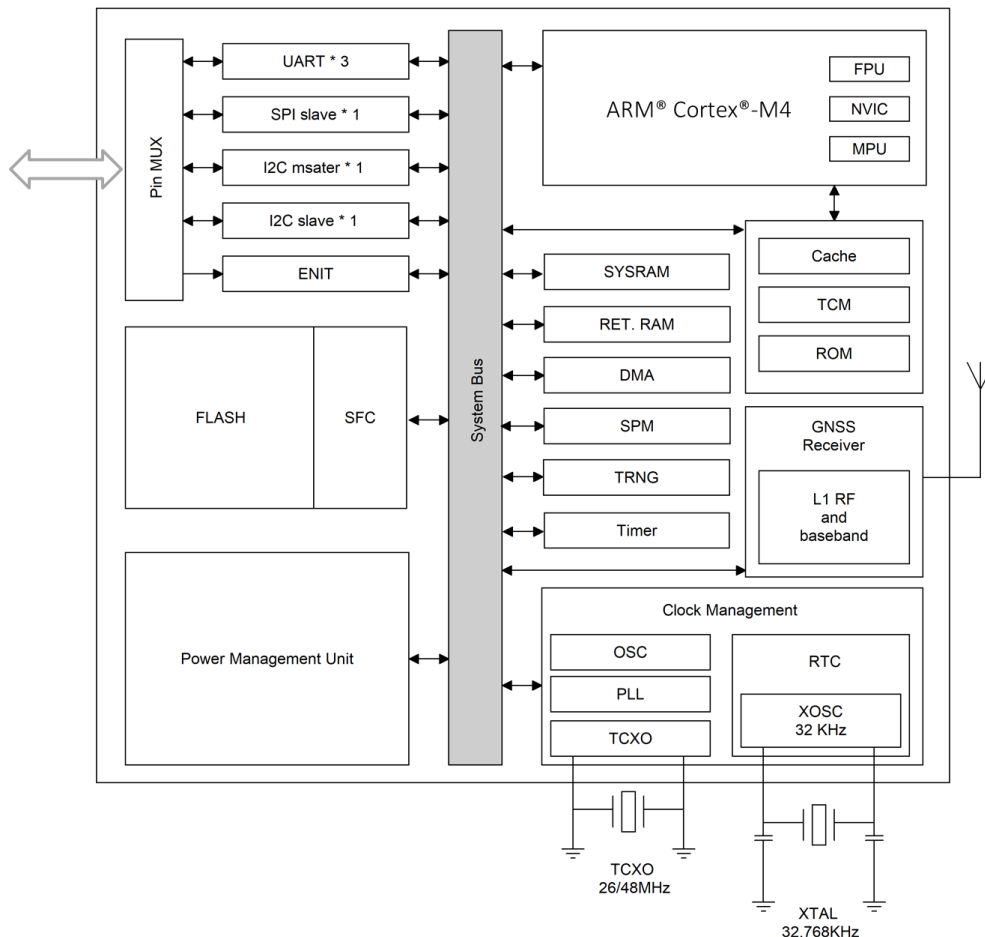

Figure 1: Block Diagram

### 3. Module Pin Assignment

The module is equipped with a 24-pin SMT pad that connects to your application platform. Sub-interfaces included in the pad are described in details in the following chapters

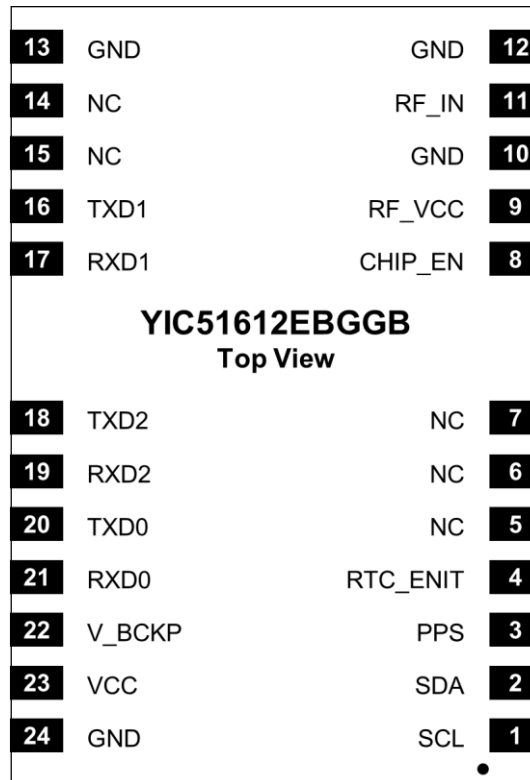

Figure 2: Pin Assignment

## 3.1 Pin Descriptions

| Pin NO. | Pin Name | Remark   |
|---------|----------|--|
| 1       | SCL      | I2C serial clock. Leave unconnected if not used.   |
| 2       | SDA      | I2C serial data. Leave unconnected if not used.  |
| 3       | PPS      | Time pulse (1PPS) (if not used, must be left floating)   |
| 4       | RTC_EINT | Interrupt pin; If the external high level is more than 10ms, the module exits the RTC mode (no connection when not in use) |
| 5       | NC       | No connection  |
| 6       | NC       | No connection  |
| 7       | NC       | No connection  |
| 8       | CHIP_EN  | Reset : Low level active. If unused, keep this pin open or connected in to Vcc   |
| 9       | RF_VCC   | Output power supply for external LNA or active antenna   |
| 10      | GND      | Ground   |
| 11      | RF_IN    | RF signal input  |
| 12      | GND      | Power Ground   |
| 13      | GND      | Power Ground   |
| 14      | NC       | No connection  |
| 15      | NC       | No connection  |
| 16      | TXD1     | Reserved debugging port (Idle)   |
| 17      | RXD1     | Reserved debugging port (Idle)   |
| 18      | TXD2     | Standby serial port output   |
| 19      | RXD2     | Standby serial port input  |
| 20      | TXD0     | UART serial data output  |
| 21      | RXD0     | UART serial data input   |
| 22      | V_BCKP   | Backup power supply, The V_BCKP pin can be directly supplied power by battery or connect it to VCC                         |
| 23      | VCC      | Main power supply:2.8~3.6V, 3.3V Typical   |
| 24      | GND      | Power Ground   |

## 3.2 UART Interface

The module provides one universal asynchronous receiver & transmitter serial port. The module is designed as DCE (Data Communication Equipment), following the traditional DCE-DTE (Data Terminal Equipment) connection. The module and the client (DTE) are connected through the signals shown in the following figure. It supports data baud-rate from 9600bps to 921600bps.

### UART port:

TXD: Send data to the RXD1 signal line of DTE.

RXD: Receive data from the TXD1 signal line of DTE.

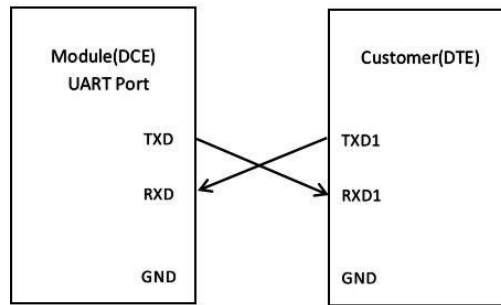

Figure 3 : Serial Port Connection

### This UART port has the following features:

- UART port can be used for NMEA Protocol output and proprietary commands input.
- The default output NMEA type setting is GGA, GLL, GSA, GSV, VTG, RMC, and ZDA.
- UART port supports the following data rates: 9600, 14400, 19200, 38400, 57600,..... 921600bps. 115200bps by default, 8 bits, no parity bit, 1 stop bit.
- Hardware flow control and synchronous operation are not supported.

The UART port does not support the RS-232 level but only CMOS level. If the module's UART port is connected to the UART/RS-232 port of a computer, it is necessary to add a level shift circuit between the module and the computer. Please refer to the following figure.

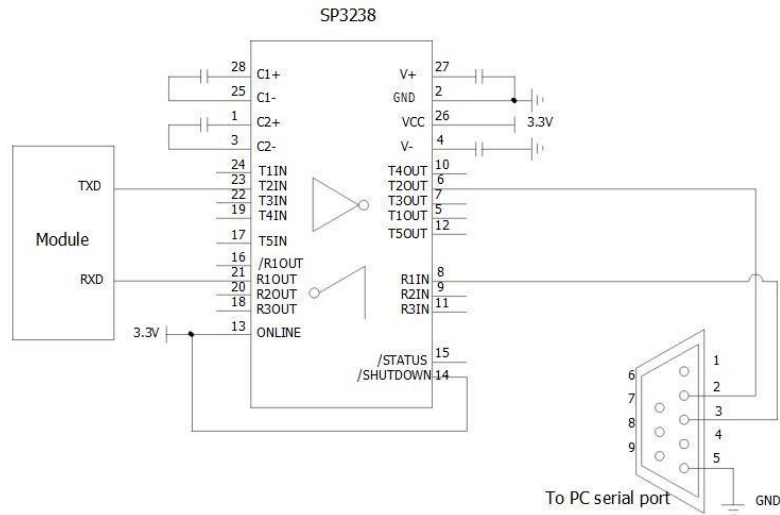

Figure 4 : RS-232 Level Shift Circuit

### 3.3 Inter-Integrated Circuit (I2C) Interface:

The module provides one Inter-Integrated Circuit port.

A serial communication bus (Serial Bus) that uses a multi-master-slave architecture. It was developed to allow motherboards, mobile phones and embedded systems to connect low-speed peripheral devices. It is mainly used in communication between chips (board-to-board).

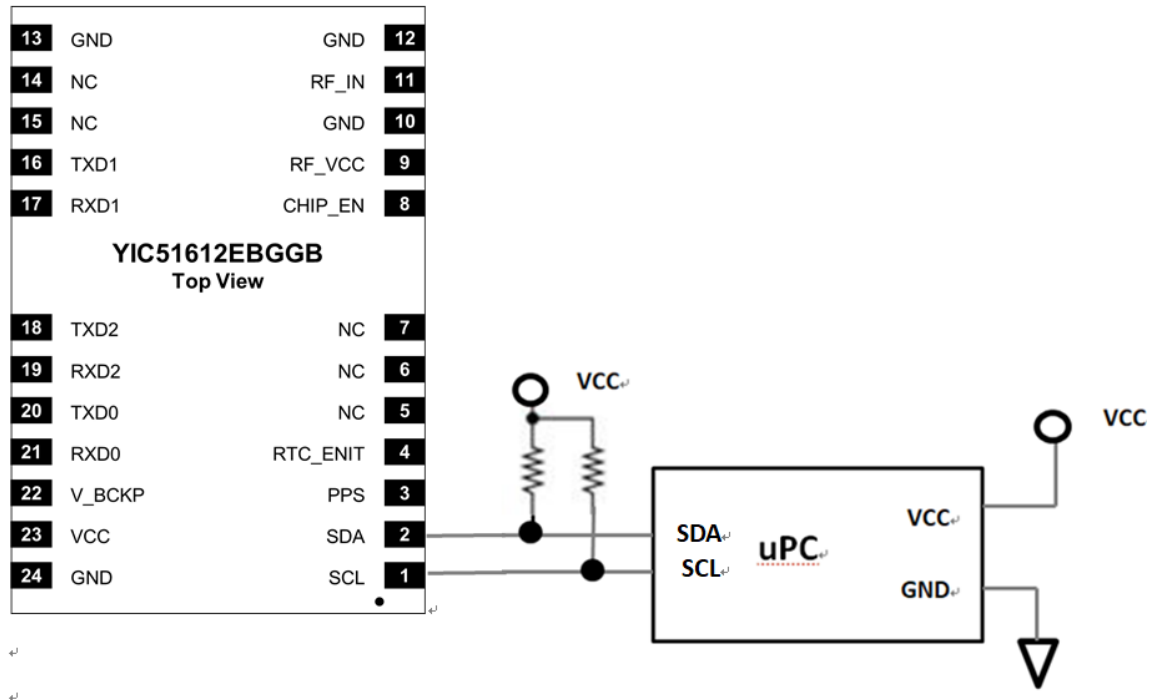
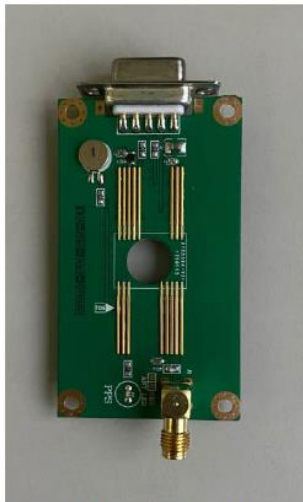

Figure 5 : I2C reference Circuit

## 3.4 Evaluation Kit (YIC EVK-1612EB)

In order to help engineers to use YIC 51612EBGGB module in the design stage, YIC supplies the EVK Kit including Evaluation Board (EVB) with micro USB serial cable, Adaptor board and GNSS External Active Antenna.

The main function of EVK is to assist engineers to immediately test and optimize software and hardware designs in order to accelerate the completion of the best product.



Main Board



Adaptor Board



USB Cable



ATGGB4336M

(GPS, QZSS, GLONASS, BDS, Galileo and SBAS and GNSS External Active Antenna)

## 4. Antenna Consideration

The YIC51612EBGGB is designed to use with active antenna, and passive antenna with higher antenna gain.

Passive ceramic patch antenna is low-cost and provides good sensitivity. 50-ohm output larger size ceramic patch antenna with higher antenna gain can be connected directly to RF input of the module. Usually the ceramic patch antenna and YIC51612EBGGB are mounted on opposite side of the PCB to reduce possibility of picking up digital noise. To improve signal reception performance, use larger ground plane under the patch antenna if possible; larger the ground plane, larger the overall antenna gain. The center frequency of the ceramic patch antenna changes with ground plane size. For optimal L1 operation, frequency bandwidth of the antenna needs to cover 1573MHz ~ 1606MHz respectively when mounted on the PCB. It is usual to ask the ceramic patch antenna vendor to select or tune a patch antenna that best matches the customer PCB.

Active antenna is essentially a passive antenna with built-in LNA and a coaxial cable to connect the antenna to the module. It has the flexibility of being located remotely from the module, but requires antenna power. Active antenna usually costs more than passive patch antenna, but the performance in low signal environments is usually better. Active antenna with gain of 10 ~ 28dB and noise figure less than 1.5dB can be used with YIC51612EBGGB

| Antenna Type             | Passive                                   | Active                                    |
|--------------------------|---|---|
| GPS&QZSS Frequency (MHz) | 1575.42 +/- 2 (L1)                        | 1575.42 +/- 2 (L1)                        |
| BDS Frequency (MHz)      | 1561 .098+/- 2(B1)<br>1575.42 +/- 2 (B1C) | 1561 .098+/- 2(B1)<br>1575.42 +/- 2 (B1C) |
| GLONASS Frequency (MHz)  | 1602MHz +/- 4(L1)                         | 1602MHz +/- 4(L1)                         |
| GALILEO Frequency (MHz)  | 1575.42 +/- 2 (E1)                        | 1575.42 +/- 2 (E1)                        |
| VSWR                     | < 2 (typical)                             | < 2 (typical)                             |
| Polarization             | RHCP                                      | RHCP                                      |
| Antenna Gain             | > 0dBi                                    | > -2dBi                                   |
| LNA Gain                 |   | 15 ~ 20dB (typical)                       |
| Noise Figure             |   | < 1.5dB                                   |
| Total Gain               |   | > 13dBi                                   |



## 4.1 Recommended Antenna

### 4.1.1 External Active Antenna : ATGGB series

ATGGB4336M



### 4.1.2 Internal Active Antenna : ATIGGB series

ATIGGB2540

ATIGGB1840

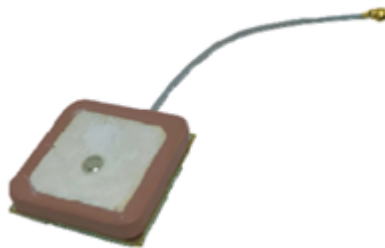

### 4.1.3 Internal Patch Antenna :

ATPGGBR2540A

ATPGGBR1840A



## 4.1.4 FPC antenna

ATIFGGBL5-4020

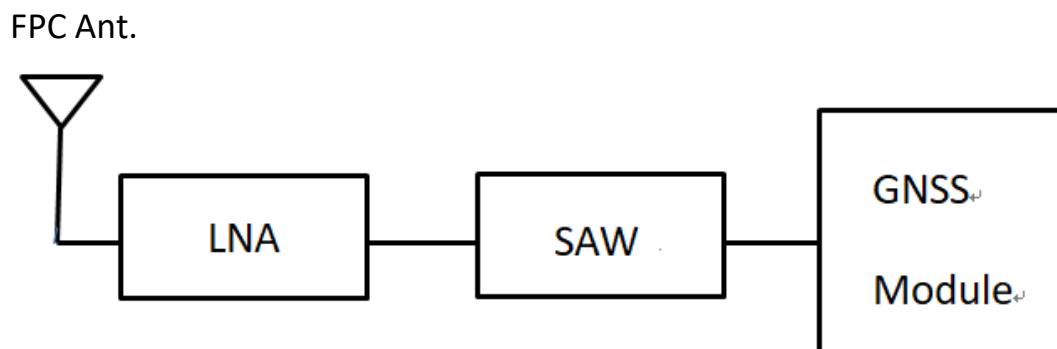
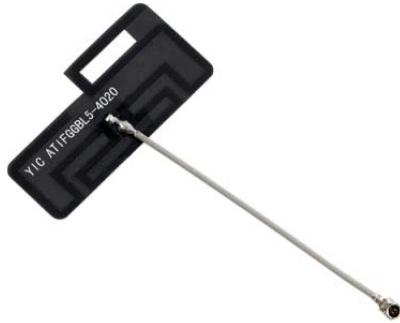

## 5. Power Supply Requirement

YIC51612EBGGB requires a stable power supply, avoid ripple on VCC pin (<50mVpp). Power supply noise can affect the receiver's sensitivity. Bypass capacitors of 10uF and 0.1uF is recommended to be placed close to the module VCC pin; the values could be adjusted according to the amount and type of noise present on the supply line.

## 6. Backup Supply

The purpose of backup supply voltage pin (VBAT) is to keep the SRAM memory and the RTC powered when the module is powered down. This enables the module to have a faster time-to-first-fix when the module is powered on again. The backup current drain is less than 50μA. In normal powered on state, the internal processor access the SRAM and current drain is higher in active mode

## 7. 1PPS Output

When using four or more satellites for 3D positioning, the rising edge of the pulse generating 1 pulse per second (Duration: 800u seconds) on 1PPS pins is aligned with the UTC seconds, and the accuracy is about 20nS. When it is not positioned, it outputs a constant low pulse.

## 8. PCB Layout Guidelines

### 8.1 Separate RF and digital circuits into different PCB regions.

It is necessary to maintain 50-ohm impedance throughout the entire RF signal path. Try keeping the RF signal path as short as possible.

Do not route the RF signal line near noisy sources such as digital signals, oscillators, switching power supplies, or other RF transmitting circuit. Do not route the RF signal under or over any other components (including YIC51612EBGGB), or other signal traces. Do not route the RF signal path on an inner layer of a multi-layer PCB to minimize signal loss. Avoid sharp bends for RF signal path. Make two 45-deg bends or a circular bend instead of a single 90-degree bend if needed.

Avoid vias with RF signal path whenever possible. Every via adds inductive impedance. Vias are acceptable for connecting the RF grounds between different layers. Each of the module's ground pins should have short trace tying immediately to the ground plane below through a via.

The bypass capacitors should be low ESR ceramic types and located directly adjacent to the pin they are for.

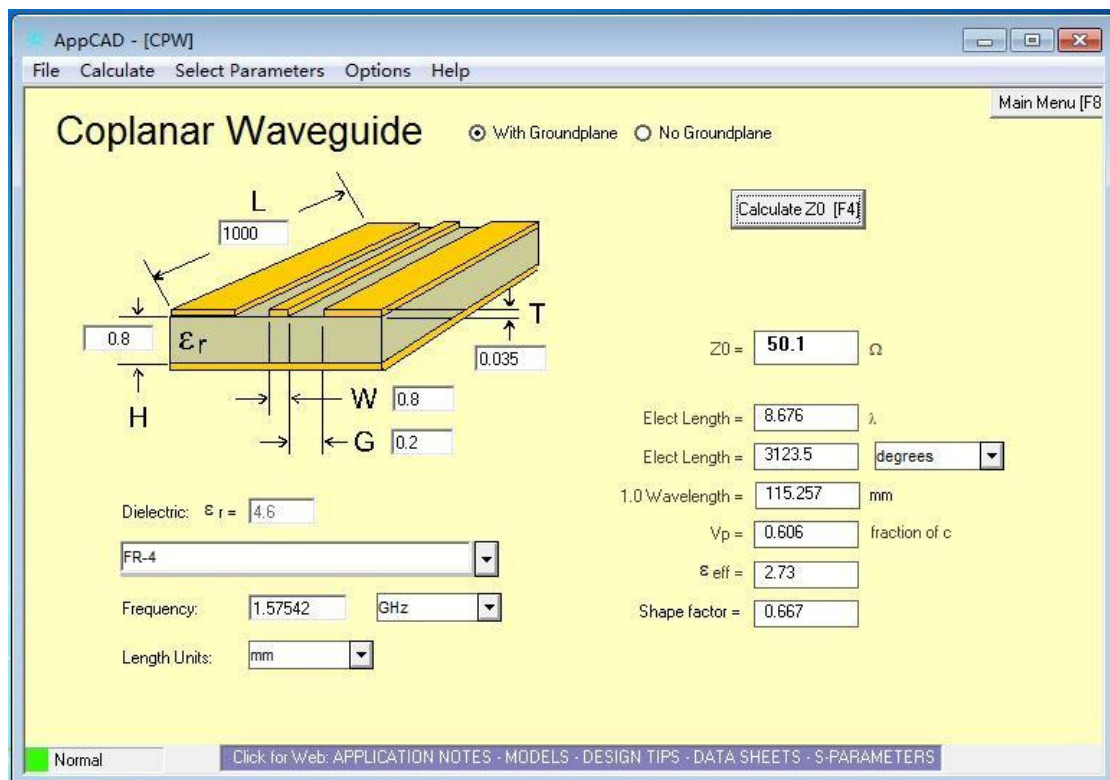

### Antenna Design

- The RF Front End part generally needs to be placed in a different mask cover (separated) from the Transceiver chip. If other PAs are used, the above requirements must also be followed.
- Inductors should be placed to avoid mutual coupling as much as possible
- The complementary paths of each group of I/O differential pairs can be as symmetrical as possible to ensure excellent phase balance and common mode rejection.
- If necessary, it is recommended to clear the metal layers under all devices and traces to ensure smaller parasitic capacitance.
- RF matching components and traces should be isolated from other circuits and traces as much as possible using GND copper.
- In addition to ensuring 50 ohm impedance control, the layout of the TX and RX lines should also be as short as possible. This can minimize line losses, which is also very important. In addition (for example), in terms of Layer distribution, the TX line can go through the TOP layer, refer to the GND of Layer 2. The RX line can go through Layer 4, refer to the GND plane of Layer 3 and Layer 5

## 8.2 Antenna Placement on PCB Design Guide (If the design uses patch antenna )

The radiation characteristic of antenna depends on various factors, such as the size, shape of PCB and dielectric constant of components nearby. It is recommended to follow the rules listed below.

- keep the module & Antenna at least 6mm away from the nearest edge of the mother board, that is, it is better to be placed in the center of the mother board.

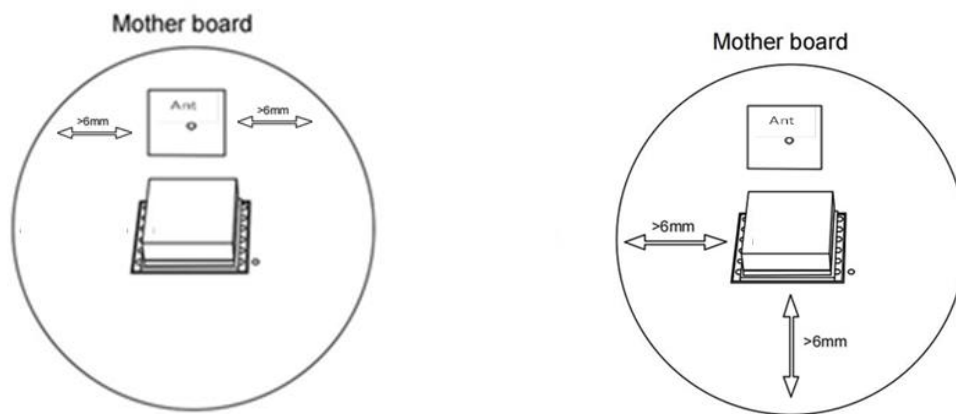

Figure 6: Recommended Distance between Module and Mother Board Edges

- Make sure the antenna points to the sky.
- The performance of embedded patch antenna depends on the actual size of the ground plane around the module. It is recommended to design a 35mm×35mm ground plane as shown below. Meanwhile, do not put any components especially tall components in the areas whenever possible. (Interfering vias is not allowed either).

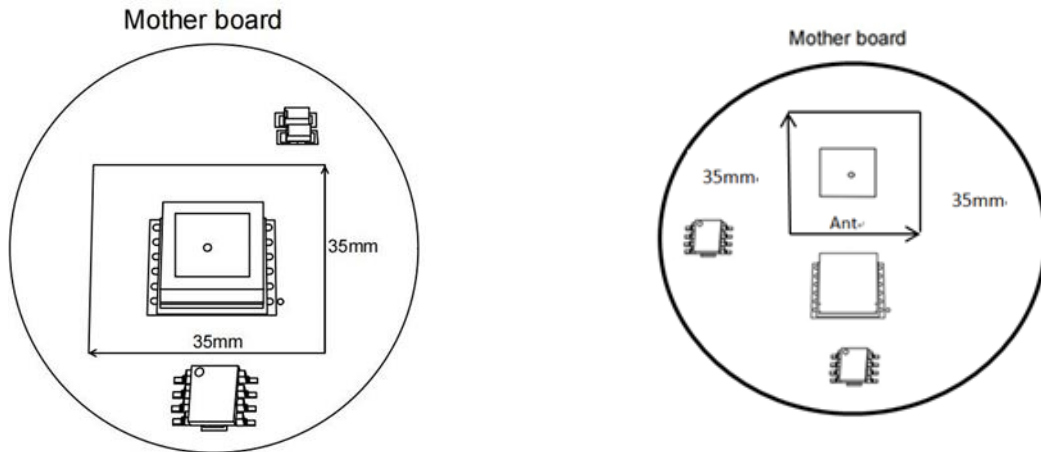

Figure 7: Recommended Ground Plane

- Keep the patch antenna at least 13mm away from other tall metal components. Otherwise, the antenna performance will be affected.

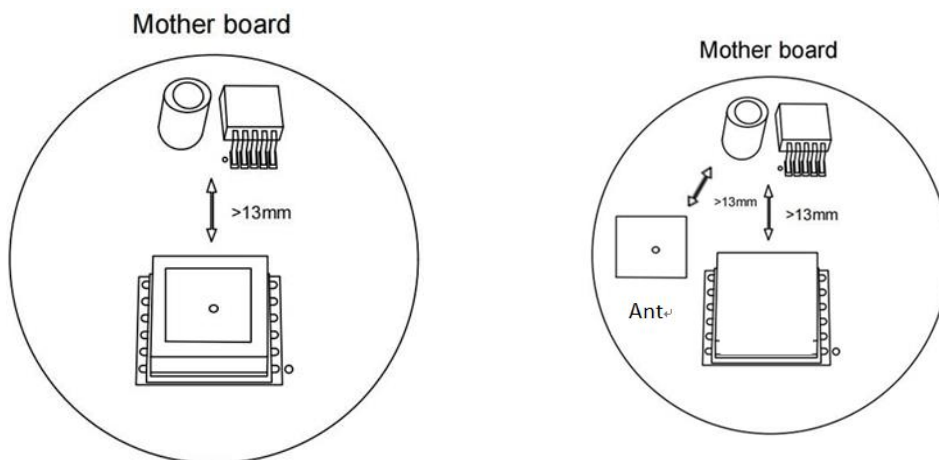

Figure 8: Recommended Distance between Module and Tall Metal Components

- Make sure the microcontroller, crystal, and other high speed components and interfaces are placed on the opposite side of the module and GPS antenna, and keep them away from the module as far as possible, such as in diagonal position of the mother board.

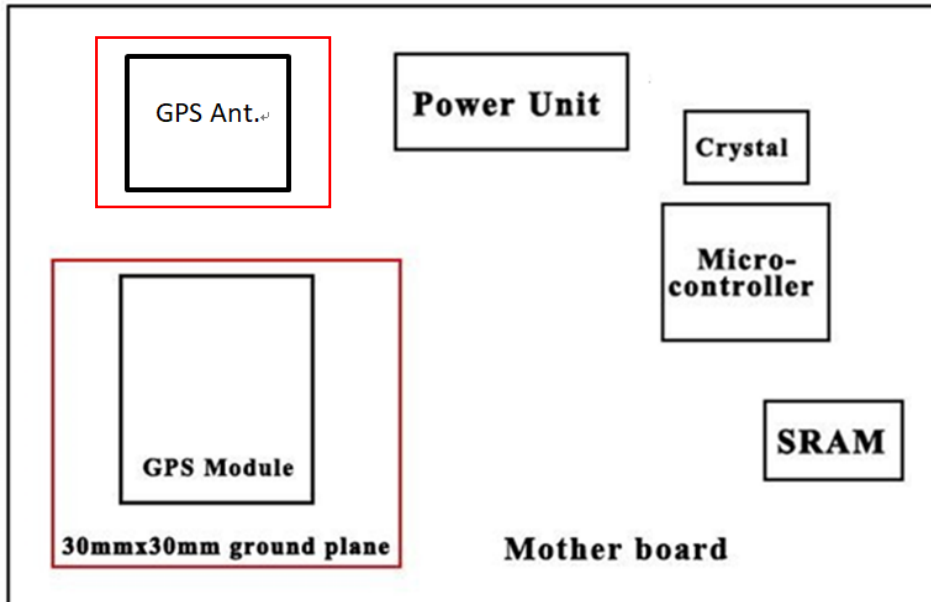

Figure 9: Recommended Placement of GNSS Antenna and Module



- Make sure interfering signals (USB, Crystal, etc.) are in inner layer and shielded by ground plane, and keep them and their vias far away from the module.
- Make sure RF system such as BT/WIFI/GSM is on the opposite side of the module, and keep them away from the module & Antenna as far as possible, such as in diagonal position of the board.

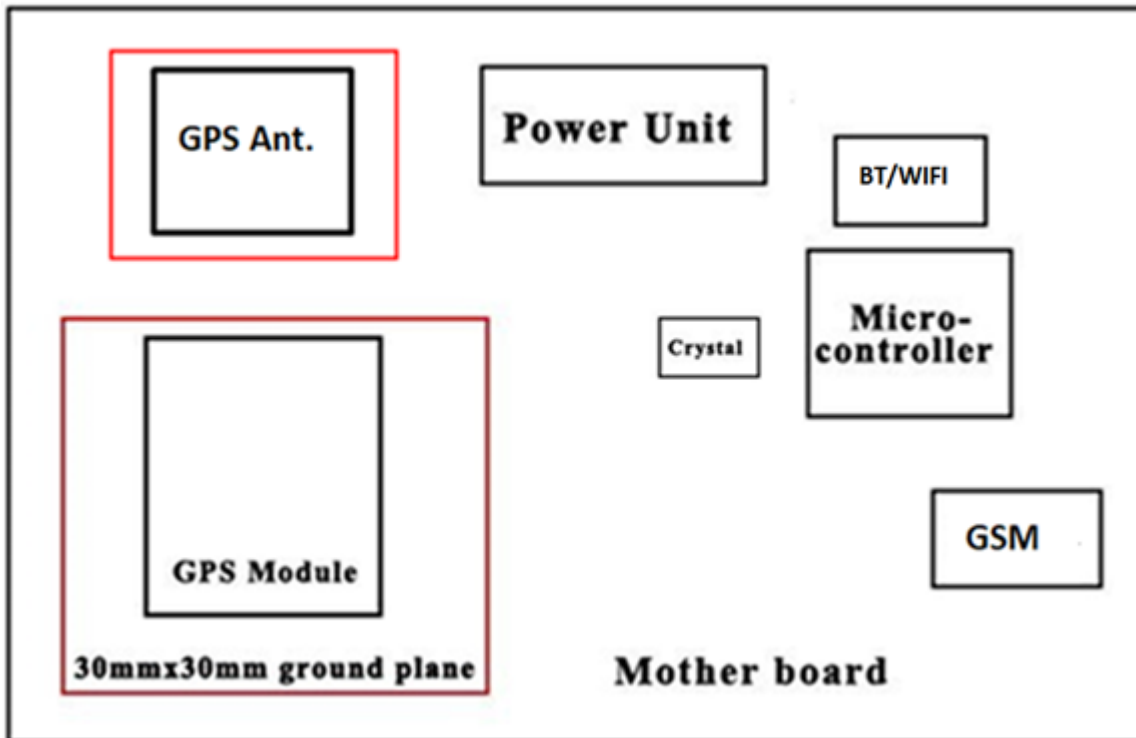

Figure 10: Recommended Placement of GNSS Module with RF System

- Keep DC/DC far away from the module
- Device enclosure should be made of non-metal materials especially for those which are around antenna area. The minimum distance between antenna and enclosure is 3mm.
- The RF part of GPS & GLONASS & Beidou module is sensitive to temperature. please keep them away from heat-emitting circuit.
- It is recommended to reserve an integrate ground layer to isolate GPS & GLONASS & Beidou module from others.

- Module's enclosure material choice has a significant impact on module's performance. Any metallization or conductive materials as flat cables above module antenna or at close vicinity can degrade GPS signals significantly or eliminate it completely. Plastic materials with high dielectric constant and dielectric loss affect antenna frequency response and its return loss. Preferable materials are those used for RADOMs and special plastics for RF applications.

## 8.3 External Active Antenna Circuit

The following figure is a typical reference design with active antenna. In this mode, DC on the RF\_IN pin is powered by VCC\_RF Pin and supplies power to the external active antenna.

$\pi$  model match network :

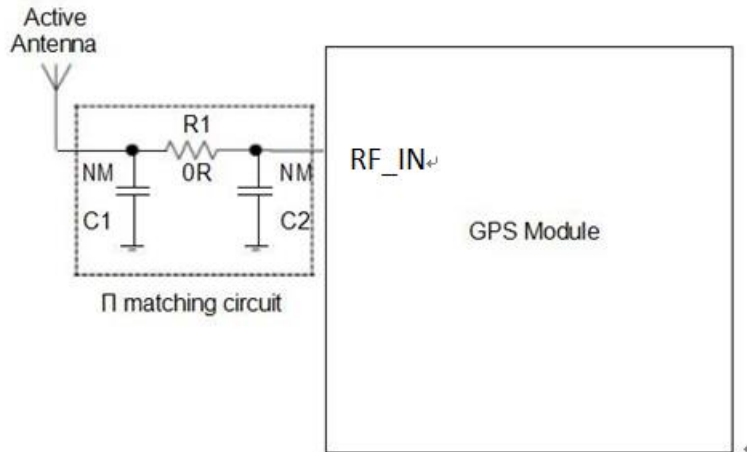

Figure 11: Reference Design for Active Antenna

C1, R1, C2 are reserved matching circuit for antenna impedance modification. By default, C1 and C2 are not mounted; R1 is 0 ohm. In this mode, R1 must not be capacitance, as current will stream through R1 to the active antenna. C1 and C2 must not be inductance or resistance to avoid short circuit.

The impedance of RF trace line in main PCB should be controlled as 50 Ohm, and the trace length should be kept as short as possible.

The following figure is a typical reference design with active antenna. In this mode, DC on the RF\_IN pin is powered by VCC\_RF Pin and supplies power to the external active antenna.

T model match network :

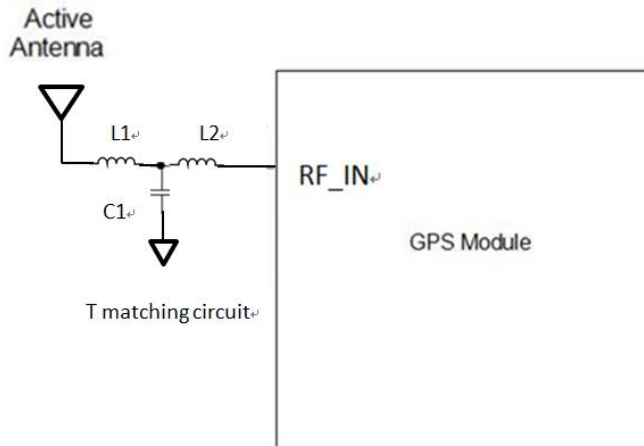
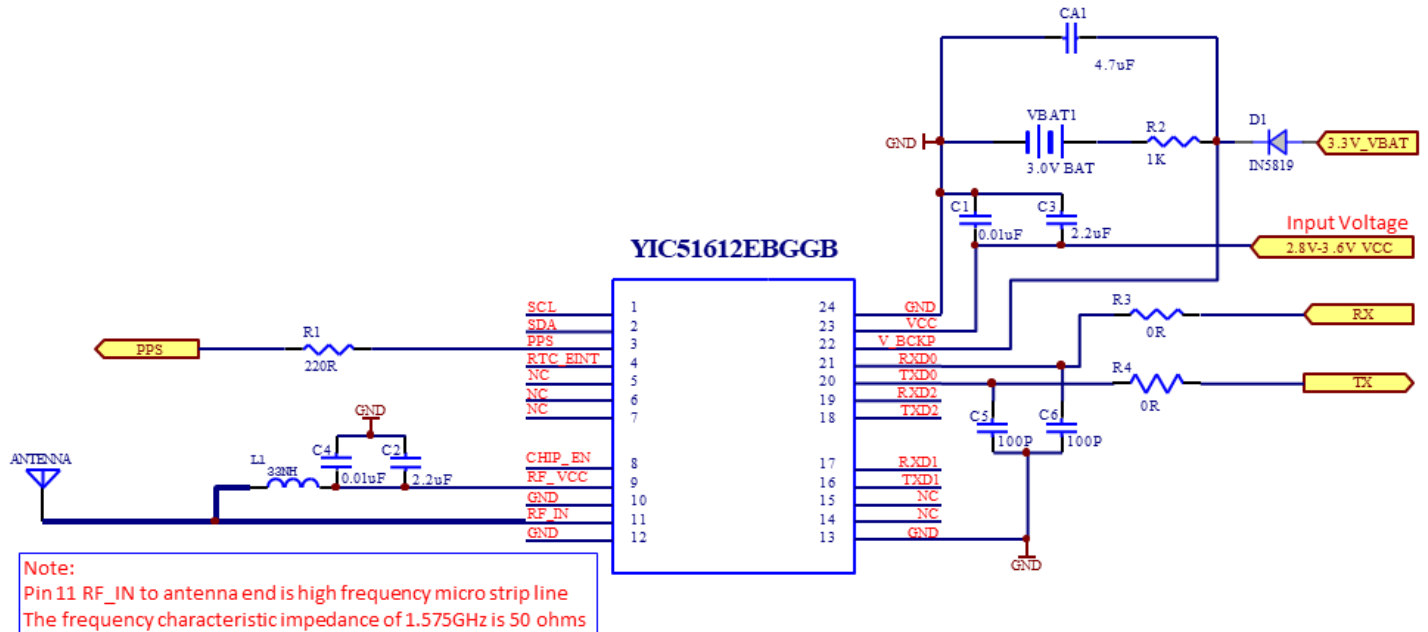

Figure 12: Reference Design for Active Antenna

L1, C1, L2 are reserved matching circuit for antenna impedance modification. By default, C1 is not mounted; L1 and L2 are 0 H.

The impedance of RF trace line in main PCB should be controlled as 50 Ohm, and the trace length should be kept as short as possible.

## 9. Application Circuit



- Patch Antennas larger than 18x18 may not require an additional LNA/ SAW Filter

## 10. ESD handling precautions and Reliability

### 10.1 Electrostatic Discharge

YIC51612EBGGB series modules are Electrostatic Sensitive Devices (ESD). Observe precautions for handling! Failure to observe these precautions can result in severe damage to the GPS receiver!

GPS receivers are Electrostatic Sensitive Devices (ESD) and require special precautions when handling. Particular care must be exercised when handling patch antennas, due to the risk of electrostatic charges. In addition to standard ESD safety practices, the following measures should be taken into account whenever handling the receiver:

- Unless there is a galvanic coupling between the local GND (i.e. the work table) and the PCB GND, then the first point of contact when handling the PCB must always be between the local GND and PCB GND.
- Before mounting antenna patch, connect ground of the device. When handling the RF pin, do not come into contact with any charged capacitors and be careful when contacting materials that can develop charges (e.g. patch antenna ~10pF, coax cable ~50-80pF/m, soldering iron.....)
- To prevent electrostatic discharge through the RF input, do not touch any exposed antenna area. If there is any risk that such exposed antenna area is touched in non ESD protected work area, implement proper ESD protection measures in the design.
- When soldering RF connectors and patch antennas to the receiver's RF pin, make sure to use an ESD safe soldering iron (tip).



Table A: ESD Endurance Table (Temperature : 25°C, Humidity: 45%)

| Pin    | Contact Discharge | Air Discharge |
|--------|-------------------|---------------|
| RF_IN  | ±5KV              | ±10KV         |
| VCC    | ±5KV              | ±10KV         |
| UART   | ±3KV              | ±6KV          |
| Others | ±2KV              | ±4KV          |

## 11. Mechanical Dimensions

This chapter describes the mechanical dimensions of the module  
 Recommended land pattern dimensions

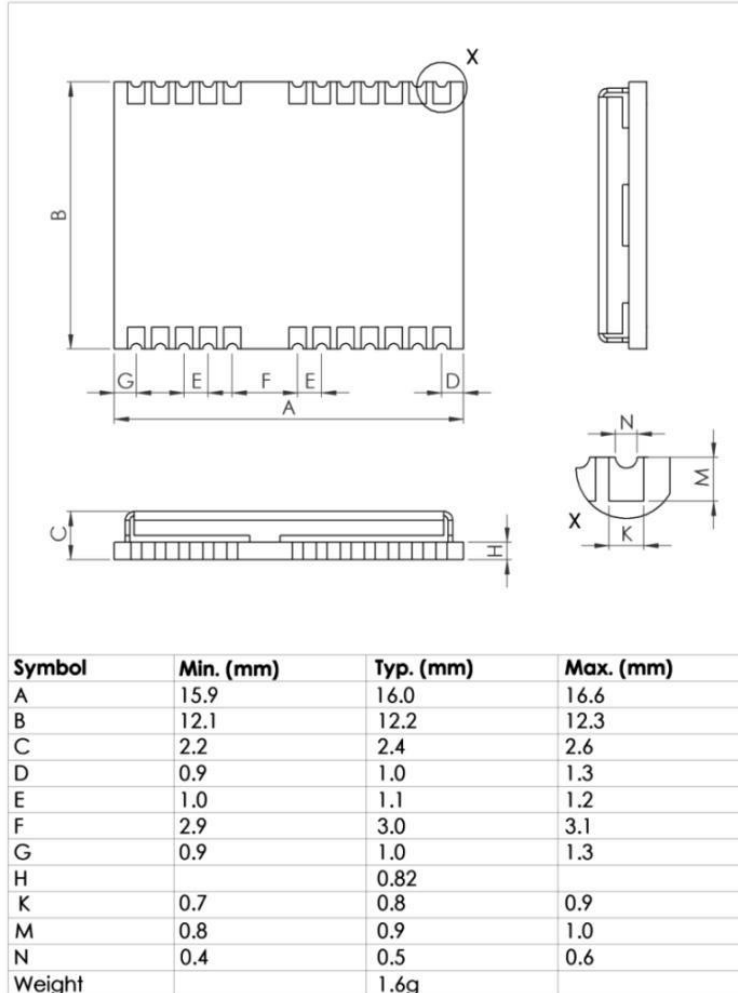

Figure 13 : Mechanical Dimensions



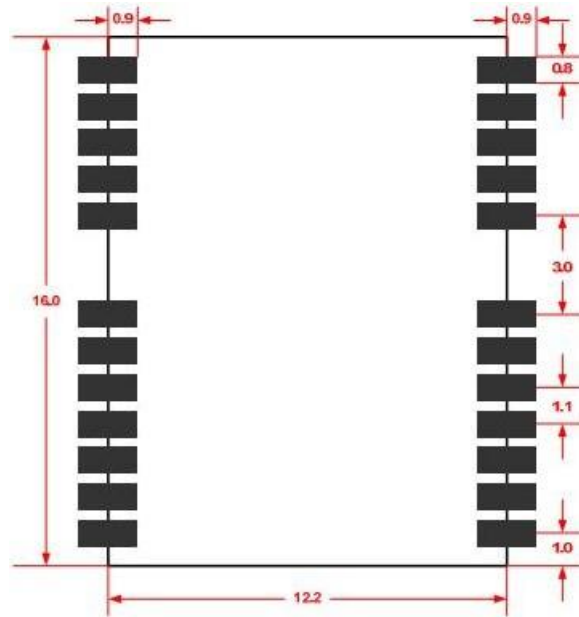

Figure 14: Reference Charging Size for PCB (unit: mm)

## 12. Manufacturing, Packaging and Ordering Information

### 12.1. Assembly and Soldering

YIC51612EBGGB module is intended for SMT assembly and soldering in a Pb-free reflow process on the top side of the PCB. It is suggested that the minimum height of solder paste stencil is 100um to ensure sufficient solder volume. Pad openings of paste mask can be increased to ensure proper soldering and solder wetting over pads. It is suggested that the peak reflow temperature is 220~240°C (for SnAg3.0Cu0.5 alloy). The absolute maximum reflow temperature is 260°C. To avoid damage to the module when it is repeatedly heated, it is suggested that the module should be mounted after reflow soldering for the other side of PCB has been completed. Recommended reflow soldering thermal profile is shown below:

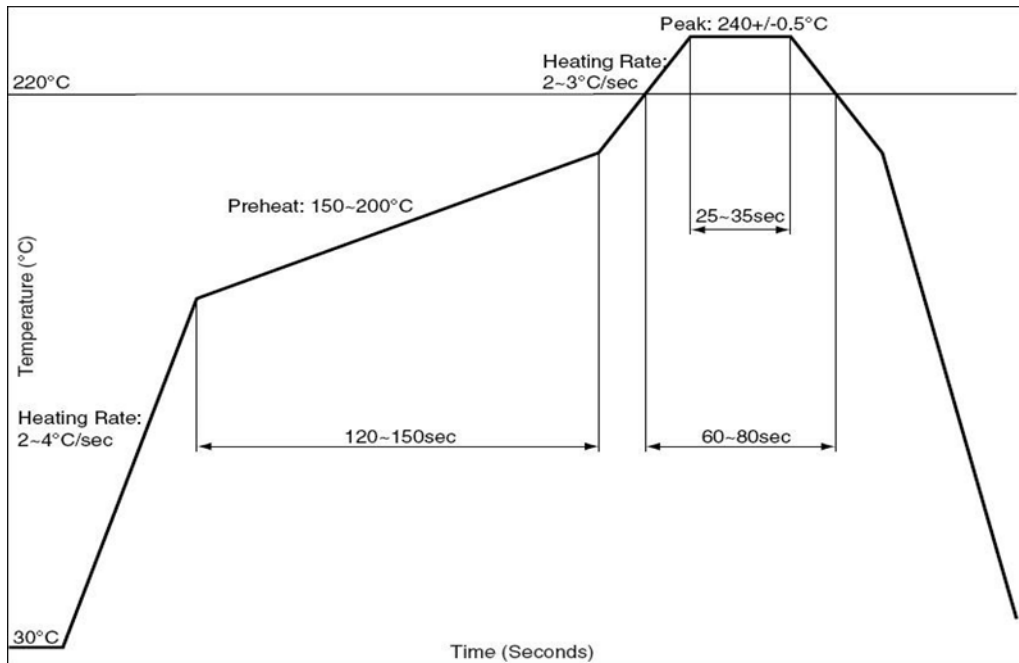

Figure 15 : Recommended Reflow Soldering Thermal Profile

## 12.2. Moisture Sensitivity

YIC51612EBGGB module is sensitive to moisture. To prevent YIC516129EBGGB from permanent damage during reflow soldering, baking before reflow soldering is required in following cases:

- Humidity indicator card: One or more indicating spots are no longer blue.
- The seal is opened and the module is exposed to excessive humidity.

YIC51612EBGGB shall be baked for 192 hours in a cryogenic environment at  $40^{\circ}\text{C}+5^{\circ}\text{C}/-0^{\circ}\text{C}$  and  $<5\%RH$ , or for 24 hours in a high-temperature environment at  $125^{\circ}\text{C}\pm 5^{\circ}\text{C}$ . As the plastic packaging tape is not heat-resistant, the module should be removed from the tape before baking, otherwise, the tape will be damaged due to high temperature heating, you can also refer to the actual production technology of the SMT factory.

## 12.3 Tape and Reel Packaging

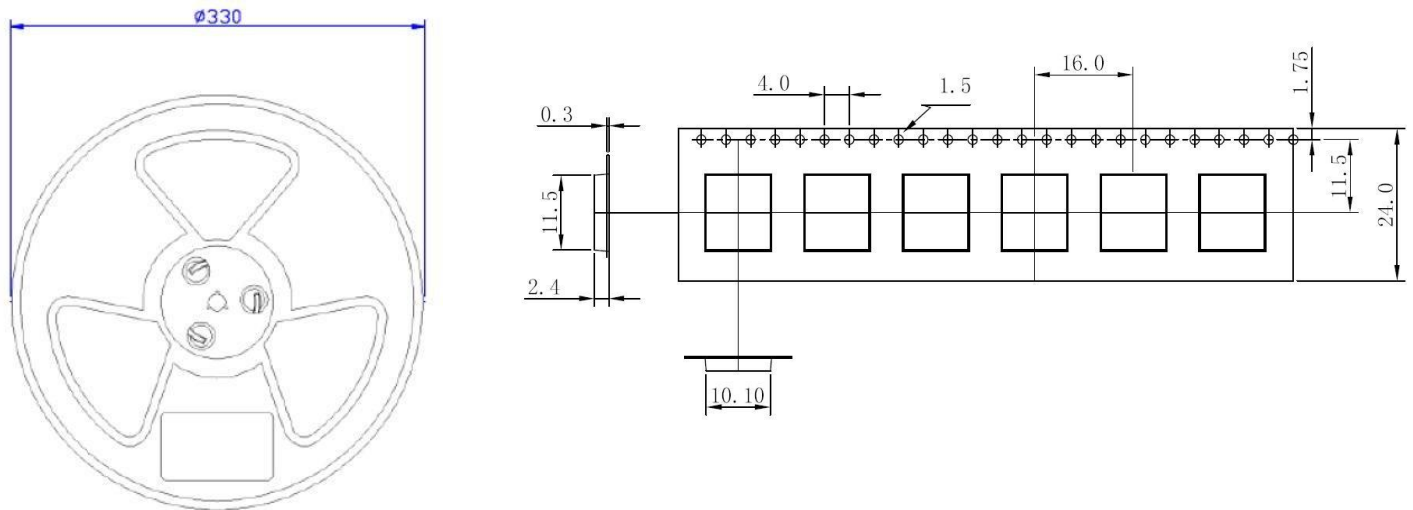

Unit: mm

Quantity per reel: 1000pcs

Length per reel: 16m

Figure 16 : Tape and Reel Specification

## 13. Software Protocol

The output protocol supports NMEA-0183 standard. The implemented messages include GGA, GLL, GSA, GSV, VTG, RMC, GST and ZDA messages. The NMEA message output has the following sentence structure: \$AACCC, c-c\*hh

The detail of the sentence structure is explained in Table 1.

Table 1: The NMEA sentence structure

| character | HEX  | Description  |
|-----------|------|--|
| "\$"      | 24   | Start of sentence.   |
| Aacc      |      | Address field. "aa" is the talker identifier. "cc" identifies the sentence type. |
| ","       | 2C   | Field delimiter.   |
| C-c       |      | Data sentence block.   |
| "*"       | 2A   | Checksum delimiter.  |
| Hh        |      | Checksum field.  |
| <CR><LF>  | 0DOA | Ending of sentence. (carriage return, line feed)                                 |

### Overview of NMEA messages

| NMEA                                     | Description   |
|--|---|
| \$GNGGA                                  | Time, position, and fix related data of the receiver.   |
| \$GNGLL                                  | Position, time and fix status.  |
| \$GNNSA                                  | Used to represent the ID of satellites which are used for position fix. When GPS & GLONASS & Galileo & BDS satellites are used for positioning solutions, the ID of available positioning satellites is counted and output with multiple statements.  |
| \$GPGSV<br>\$GLGSV<br>\$GAGSV<br>\$GBGSV | Satellite information about elevation, azimuth and CNR, satellites are used in position solution, \$GPGSV sentence is used for GPS satellites, a \$GLGSV sentence is used for GLONASS satellites, \$GAGSV sentence is used for GALILEO satellites. And \$GBGSV sentence is used for BDS satellites. |
| \$GNRMC                                  | Time, date, position, course and speed data.  |
| \$GNVTG                                  | Course and speed relative to the ground.  |
| \$GNZDA                                  | UTC, day, month and year and time zone.   |

The formats of the supported NMEA messages are described as follows:

## 13.1 GGA – Global Positioning System Fix Data

Time, position and fix related data for a GNSS receiver.

Structure: \$GNGGA,hhmmss.sss,ddmm.mmmm,a,dddmm.mmmm,a,x,xx,x.x,x.x,M,x.x,M,x.x,xxxx\*hh

For example: \$GNGGA,175258.000,2447.0870,N,12100.5221,E,2,15,0.7,95.2,M,19.6,M,,0000\*72

| Field | Name                         | Example     | Description   |
|-------|------------------------------|-------------|---|
| 1     | UTC Time                     | 175258.000  | UTC of position in hhmmss.sss format, (000000.000 ~ 235959.999)   |
| 2     | Latitude                     | 2447.08700  | Latitude in ddmm.mmmmm format Leading zeros transmitted   |
| 3     | N/S Indicator                | N           | Latitude hemisphere indicator, 'N' = North, 'S' = South   |
| 4     | Longitude                    | 12100.52210 | Longitude in dddmm.mmmmm format Leading zeros transmitted   |
| 5     | E/W Indicator                | E           | Longitude hemisphere indicator, 'E' = East, 'W' = West  |
| 6     | Quality Indicator            | 2           | Quality Indicator<br>0: position fix unavailable<br>1: valid position fix, SPS mode<br>2: valid position fix, differential GPS mode<br>3: GPS PPS Mode, fix valid<br>6: Estimated (dead reckoning) Mode |
| 7     | Satellites Used              | 15          | Number of satellites in use, (00 ~ 56)  |
| 8     | HDOP                         | 0.7         | Horizontal dilution of precision, (0.0 ~ 99.9)  |
| 9     | Altitude                     | 95.2        | mean sea level (geoid), (-9999.9 ~ 17999.9)   |
| 10    | Geoidal Separation           | 19.6        | Geoidal separation in meters  |
| 11    | Age of Differential GPS data |             | Age of Differential GPS data<br>NULL when DGPS not used   |
| 12    | DGPS Station ID              | 0000        | Differential reference station ID, 0000 ~ 1023  |
| 13    | Checksum                     | 72          |   |

## 13.2 GLL – Latitude/Longitude

Latitude and longitude of current position, time, and status.

Structure: \$GNGLL,ddmm.mmmm,a,dddmm.mmmm,a,hhmmss.sss,A,a\*hh

For example: \$GNGLL,2447.0870,N,12100.5221,E,175258.000,A,D\*42

| Field | Name           | Example     | Description   |
|-------|----------------|-------------|---|
| 1     | Latitude       | 2447.08700  | Latitude in ddmm.mmmmm format Leading zeros transmitted   |
| 2     | N/S Indicator  | N           | Latitude hemisphere indicator 'N' = North<br>'S' = South  |
| 3     | Longitude      | 12100.52210 | Longitude in dddmm.mmmmm format Leading zeros transmitted   |
| 4     | E/W Indicator  | E           | Longitude hemisphere indicator 'E' = East<br>'W' = West   |
| 5     | UTC Time       | 175258.000  | UTC time in hhmmss.sss format (000000.000 ~ 235959.999)   |
| 6     | Status         | A           | Status, 'A' = Data valid, 'V' = Data not valid  |
| 7     | Mode Indicator | D           | Mode indicator<br>'N' = Data not valid<br>'A' = Autonomous mode<br>'D' = Differential mode<br>'E' = Estimated (dead reckoning) mode |
| 8     | Checksum       | 42          |   |

## 13.3 GSA – GNSS DOP and Active Satellites

GNSS receiver operating mode, satellites used in the navigation solution reported by the GGA sentence and DOP values.

Structure: \$GNGSA,A,x,xx,xx,xx,xx,xx,xx,xx,xx,xx,xx,x.x,x.x,x.x,x\*hh

For example: \$GNGSA,A,3,21, 12,15,18,20,24,10,32,25,13,,,1.2,0.7,1.0,1\*18

| Field | Name                | Example                                     | Description  |
|-------|---------------------|---|--|
| 1     | Mode                | A   | Mode<br>'M' = Manual, forced to operate in 2D or 3D mode<br>'A' = Automatic, allowed to automatically switch 2D/3D   |
| 2     | Mode                | 3   | Fix type<br>1 = Fix not available<br>2 = 2D<br>3 = 3D  |
| 3     | Satellite used 1~12 | 21, 12, 15, 18,<br>20, 24, 10,<br>32,25, 13 | 01 ~ 32 are for GPS; 33 ~ 64 are for WAAS (PRN minus 87); 193 ~ 197 are for QZSS; 65 ~ 88 are for GLONASS (GL PRN) ; 01 ~ 36 are for GALILEO (GA PRN); 01 ~ 37 are for BDS (BD PRN). GPS, GLONASS, GALILEO and BDS satellites are differentiated by the. GNSS system ID in table 1. Maximally 12 satellites are included in each GSA sentence. |
| 4     | PDOP                | 1.2   | Position dilution of precision (0.0 to 99.9)   |
| 5     | HDOP                | 0.7   | Horizontal dilution of precision (0.0 to 99.9)   |
| 6     | VDOP                | 1.0   | Vertical dilution of precision (0.0 to 99.9)   |
| 7     | GNSS System ID      | 1   | 1 for GPS, 2 for GLONASS, 3 for GALILEO, 4 for BDS   |
| 8     | Checksum            | 18  |  |

## 13.4 GSV – GNSS Satellites in View

Number of satellites (SV) in view, satellite ID numbers, elevation, azimuth, and SNR value. Four satellites maximum per transmission.

Structure: \$GPGSV , x , x , xx , xx , xx , xx , xx , ... , xx , xx , xx , xx , xx , x\*hh

For example: \$GPGSV , 4,1 , 13 , 02,72 , 109 , 43,24 , 69,035 , 48,18 , 52,330 , 42,21 , 49,246 , 43 , 1\*69

| Field | Name               | Example | Description  |
|-------|--------------------|---------|--|
| 1     | Number of message  | 4       | Total number of GSV messages to be transmitted (1-5)   |
| 2     | Sequence number    | 1       | Sequence number of current GSV message   |
| 3     | Satellites in view | 13      | Total number of satellites in view (00 ~ 20)   |
| 4     | Satellite ID       | 02      | 01 ~ 32 are for GPS; 33 ~ 64 are for WAAS (PRN minus 87); 193 ~ 197 are for QZSS; 65 ~ 88 are for GLONASS (GL PRN) ; 01 ~ 36 are for GALILEO (GA PRN); 01 ~ 37 are for BDS (BD PRN). GPS, GLONASS, GALILEO and BDS satellites are differentiated by the GNSS system ID in table 1. Maximally 12 satellites are included in each GSA sentence |
| 5     | Elevation          | 72      | Satellite elevation in degrees, (00 ~ 90)  |
| 6     | Azimuth            | 109     | Satellite azimuth angle in degrees, (000 ~ 359 )   |
| 7     | SNR                | 43      | C/No in dB (00 ~ 99)<br>Null when not tracking   |
| 8     | Signal ID          | 1       | 1 for L1/CA  |
| 9     | Checksum           | 69      |  |



## 13.5 RMC – Recommended Minimum Specific GNSS Data

Time, date, position, course and speed data provided by a GNSS navigation receiver.

Structure: \$GNRMC,hhmmss.sss,A,dddmm.mmmmm,a,dddmm.mmmmm,a,x.x,x.x,ddmmyy,,,a\*hh

For example: \$GNRMC,175258.000,A,2447.0870,N,12100.5220,E,000.0,000.0,220617,,,D\*75

| Field | Name               | Example     | Description   |
|-------|--------------------|-------------|---|
| 1     | UTC time           | 175258.000  | UTC time in hhmmss.sss format (000000.00 ~ 235959.999)  |
| 2     | Status             | A           | Status<br>'V' = Navigation receiver warning<br>'A' = Data Valid   |
| 3     | Latitude           | 2447.08700  | Latitude in dddmm.mmmmm format Leading zeros transmitted  |
| 4     | N/S indicator      | N           | Latitude hemisphere indicator 'N' =North 'S' = South  |
| 5     | Longitude          | 12100.52210 | Longitude in dddmm.mmmmm format Leading zeros transmitted   |
| 6     | E/W Indicator      | E           | Longitude hemisphere indicator 'E' = East 'W' = West  |
| 7     | Speed over ground  | 000.0       | Speed over ground in knots (000.0 ~ 999.9)  |
| 8     | Course over ground | 000.0       | Course over ground in degrees (000.0 ~ 359.9)   |
| 9     | UTC Date           | 220617      | UTC date of position fix, ddmmyy format   |
| 10    | Mode indicator     | D           | Mode indicator<br>'N' = Data not valid<br>'A' = Autonomous mode<br>'D' = Differential mode<br>'E' = Estimated (dead reckoning) mode |
| 11    | checksum           | 75          |   |

## 13.6 VTG – Course Over Ground and Ground Speed

The actual course and speed relative to the ground.

Structure: \$GNVTG,x.x,T,,M,x.x,N,x.x,K,a\*hh

For example: \$GNVTG,000.0,T,,M,000.0,N,000.0,K,D\*16

| Field | Name     | Example | Description  |
|-------|----------|---------|--|
| 1     | Course   | 000.0   | True course over ground in degrees (000.0 ~ 359.9)   |
| 2     | Speed    | 000.0   | Speed over ground in knots (000.0 ~ 999.9)   |
| 3     | Speed    | 000.0   | Speed over ground in kilometers per hour (000.0 ~ 1800.0)  |
| 4     | Mode     | D       | Mode indicator<br>'N' = Data not valid<br>'A' = Autonomous mode<br>'D' =Differential mode<br>'E' = Estimated (dead reckoning) mode |
| 5     | Checksum | 16      |  |

## 13.7 ZDA – TIME AND DATE

UTC, day, month, year and local time zone

Structure: \$GNZDA,hhmmss.sss,xx,xx,xxxx,xx,xx\*hh<CR><LF>

For example: \$GNZDA,175258.000,30,08,2022,00,00\*46<CR><LF>

| Field | Name               | Example    | Units | Description  |
|-------|--------------------|------------|-------|--|
| 1     | UTC time           | 175258.000 |       | UTC time in hhmmss.ss format (000000.00 ~ 235959.99) |
| 2     | UTC Day            | 30         |       | UTC time: day (01 ~ 31)                              |
| 3     | UTC Month          | 28         |       | UTC time: month (01 ~ 12)                            |
| 4     | UTC Year           | 2022       |       | UTC time: year (4 digit format)                      |
| 5     | Local zone hour    | 00         |       | Local zone hours (00 ~ +/- 13)                       |
| 6     | Local zone minutes | 00         |       | Local zone minutes (00 ~59)                          |
| 7     | Checksum           | 46         |       | Checksum   |

## 14. Appendix References

### Terms and Abbreviations

| Abbreviation | Description  |
|--------------|--|
| AGNSS        | Assisted GNSS  |
| AIC          | Active Interference Cancellation   |
| CEP          | Circular Error Probable  |
| DGPS         | Differential GPS   |
| EASY         | Embedded Assist System   |
| EGNOS        | European Geostationary Navigation Overlay Service                              |
| EPO          | Extended Prediction Orbit  |
| ESD          | Electrostatic Discharge  |
| GPS          | Global Positioning System  |
| GNSS         | Global Navigation Satellite System   |
| GGA          | GNSS Fix Data  |
| GLL          | Geographic Position – Latitude/Longitude                                       |
| GLONASS      | Global Navigation Satellite System   |
| GSA          | GNSS DOP and Active Satellites   |
| GSV          | GNSS Satellites in View  |
| HDOP         | Horizontal Dilution of Precision   |
| I/O          | Input / Output   |
| Kbps         | Kilo Bits Per Second   |
| LNA          | Low Noise Amplifier  |
| MSAS         | Multi-Functional Satellite Augmentation System                                 |
| MOQ          | Minimum Order Quantity   |
| NMEA         | National Marine Electronics Association  |
| PDOP         | Position Dilution of Precision   |
| PMTK         | MTK Proprietary Protocol   |
| PPS          | Pulse Per Second   |
| PRN          | Pseudo Random Noise Code   |
| QZSS         | Quasi-Zenith Satellite System  |
| RHCP         | Right Hand Circular Polarization   |
| RMC          | Recommended Minimum Specific GNSS Data   |
| SBAS         | Satellite-based Augmentation System  |
| SAW          | Surface Acoustic Wave  |
| SPDT         | Single-Pole Double-Throw   |
| TTF          | Time To First Fix  |
| UART         | Universal Asynchronous Receiver & Transmitter                                  |
| VDOP         | Vertical Dilution of Precision   |
| VTG          | Course over Ground and Ground Speed, Horizontal Course and Horizontal Velocity |
| WAAS         | Wide Area Augmentation System  |
| Inom         | Nominal Current  |
| Imax         | Maximum Load Current   |
| Vmax         | Maximum Voltage Value  |
| Vnom         | Nominal Voltage Value  |

|        |   |
|--------|---|
| Vmin   | Minimum Voltage Value                   |
| VIHmax | Maximum Input High Level Voltage Value  |
| VIHmin | Minimum Input High Level Voltage Value  |
| VILmax | Maximum Input Low Level Voltage Value   |
| VILmin | Minimum Input Low Level Voltage Value   |
| VImax  | Absolute Maximum Input Voltage Value    |
| VImin  | Absolute Minimum Input Voltage Value    |
| VOHmax | Maximum Output High Level Voltage Value |
| VOHmin | Minimum Output High Level Voltage Value |
| VOLmax | Maximum Output Low Level Voltage Value  |
| VOLmin | Minimum Output Low Level Voltage Value  |
|        |   |
|        |   |
|        |   |
|        |   |
|        |   |
|        |   |
|        |   |
|        |   |